



# EXPANSION JOINTS & FLEXIBLE METAL HOSES



**KLINGER  
TURKEY**



# KLINGER TURKEY

With over 45 years of experience in the design and manufacturing of expansion joints and flexible metal hoses, our engineering group is proud of offering fast and economical solutions with high quality, utilizing modern technologies.

KLINGER Turkey has been offering a wide range of expansion joints and flexible metal hoses in addition to standard types since its first days. KLINGER Turkey can design and manufacture high pressure, large diameter and various types of flexible solutions.

All of our products are designed and manufactured by our own engineers and manufacturing personnel. This ensures the quality and reliability of our products.

With over 9.000 square meter of manufacturing area and supplying to well-known customers worldwide since 1976, KLINGER Turkey is the address our customers choose when they want a fast, high quality and reliable product.

KLINGER was founded in 1886 as a family business and is known as a pioneer in sealing technology. Serving a global client base, it delivers trusted products worldwide for petro-chemical, chemical, process industries, infrastructure, and transportation applications. Today, the group comprises of 40 companies and more than 60 manufacturing, distribution and service hubs worldwide.

## **MANUFACTURING**

Bellows and hoses can be manufactured in various materials such as 304, 316, 321, 309S, 310S, 904L, Duplex 2205, Duplex 2507, Alloy 625 Alloy 825, Alloy 800H and other nickel alloys.

## **QUALITY**

KLINGER Turkey is fully committed to a quality management process with quality as a fundamental business principle. Core of the process is achieving customer satisfaction by meeting our internal and customer requirements on time.

## **DESIGN**

Designing for a wide range of parameters allows product solutions to be developed both quickly and effectively.



# Mission

Being customer oriented  
Offering fast, reliable and high quality products  
Exceeding customers' expectations

# Values

Our values are part of our DNA and serve as a compass for our actions.

# Vision

We design and manufacture expansion joints and flexible metal hoses to worldwide industry standards.  
Being a part of KLINGER group, social and environmental responsibilities are taken very seriously by KLINGER Turkey and our employees.  
We are confident that with our strong team we will continue to grow to be one of the largest expansion joint and flexible metal hose manufacturers in the world.

# CERTIFICATES

## Expansion Joints

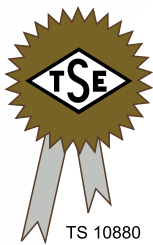

## Flexible Metal Hoses



As a part of the KLINGER Group, KLINGER Turkey has been developing, manufacturing high-quality expansion joints and flexible metal hoses in Istanbul/Turkey for more than 45 years. Via our global distribution and service network, KLINGER Turkey offers both standardized and special products, services as well as solutions for customers around the globe.

Products from KLINGER Turkey are characterized by their high level of reliability as well as by above average life cycle at a very low total cost of ownership (TCO). As a trusted solutions partner, KLINGER Turkey creates customer benefits with added value. In this regard, the focus is on the following core competences:

## ENCOMPASSING SERVICE

- » Application expertise
- » Product trainings
- » Fast quotation and order processing
- » Customer-specific solutions
- » On-site technical support



## PRODUCT SOLUTIONS

- » High level product knowledge
- » Product tests in the in-house technical center
- » A wide range of certificates and approvals



## OPERATIONAL EXCELLENCE

- » Flexible production
- » Short delivery time
- » Fast logistic support

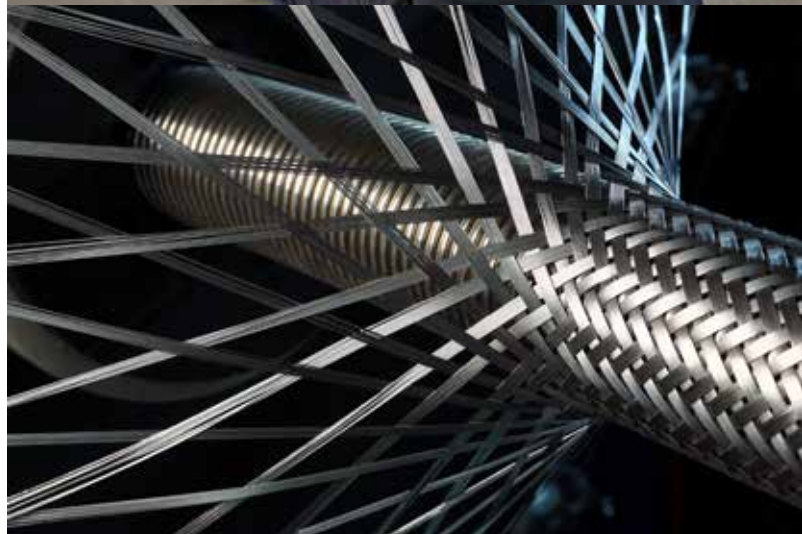

# WELD END

## Expansion Joints

Weld end expansion joints are equipped with carbon steel or stainless steel pipe connections.

Even though they can absorb movements in any direction, this type is mainly used for axial movements. If lateral movement is requested, a universal type may be more suitable. These type of expansion joints can be supplied with limit rod, liners, covers, rods, hinges or gimbals.

Available for exhaust gas, liquid medium and steam. Bellows are calculated following latest EJMA standards.

Also, weld end type expansion joints may have a double bellows which are designed for absorbing the higher lateral movements.

### Advantages

- » Economical when it is compared with other flange end expansion joints
- » No need for gaskets
- » Welded, no leakage possible

### Applications

- » Hot & Cold water pipelines
- » District heating pipelines
- » Steam pipelines
- » Shipbuilding and exhaust systems
- » Geothermal water application
- » Chemical industry
- » Iron and steel industry
- » Pulp and paper industry



## DESIGN VALUES

Bellows Material	304, 316, 321
Weld End Material	Carbon Steel, Stainless Steel
Design Pressure	2,5 barg
Design Temperature	550°C

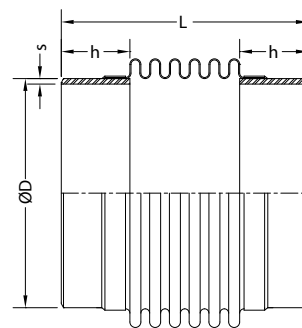

# PN 2,5

DN	Type	Length (L) (mm)	Movements		Spring Rates		Effective Area (cm <sup>2</sup> )	Weld-End		
			Axial (+/-) (mm)	Lateral (+/-) (mm)	Axial (N/mm)	Lateral (N/mm)		ØD (mm)	s (mm)	h (mm)
32	L	255	16	17	31	4	19	42,4	3	50
	S	185	8	5	57	26				
40	L	255	18	17	27	5	26	48,3	3	50
	S	185	10	5	50	29				
50	L	255	29	22	30	9	39	60,3	4	50
	S	205	20	10	44	27				
65	L	260	33	21	32	13	58	76,1	4	50
	S	205	22	9	48	45				
80	L	265	40	22	27	14	80	88,9	4	50
	S	205	24	9	46	58				
100	L	295	35	16	60	45	129	114,3	4	60
	S	225	23	6	82	166				
125	L	304	36	15	67	66	187	139,7	4	60
	S	237	26	7	85	202				
150	L	304	50	17	44	62	271	168,3	5	60
	S	225	30	6	65	274				
200	L	325	64	19	41	78	452	219,1	5	60
	S	225	40	6	58	389				
250	L	365	70	16	42	42	684	273	5	80
	S	265	40	5	68	683				
300	L	385	70	16	50	161	945	323,9	6	80
	S	265	40	4	78	1.076				
350	L	425	65	16	47	181	1.133	355,6	6	100
	S	295	35	3	102	1.993				
400	L	425	65	14	51	255	1.478	406,4	6	100
	S	300	30	2	65	1.507				
450	L	420	70	13	51	329	1.839	457,2	6	100
	S	310	35	2	80	2.001				
500	L	420	85	13	44	354	2.263	508	6	100
	S	315	40	2	72	1.931				

Please consult with our technical department for different working conditions and design parameters.

Movements are non-concurrent

## DESIGN VALUES

Bellows Material	304, 316, 321
Weld End Material	Carbon Steel, Stainless Steel
Design Pressure	6 barg
Design Temperature	400°C

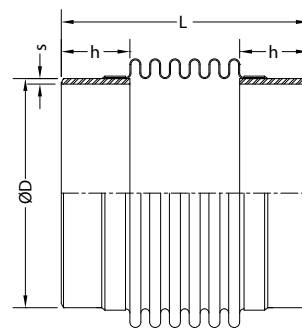

# PN 6

DN	Type	Length (L) (mm)	Movements		Spring Rates		Effective Area (cm <sup>2</sup> )	Weld-End		
			Axial (+/-) (mm)	Lateral (+/-) (mm)	Axial (N/mm)	Lateral (N/mm)		ØD (mm)	s (mm)	h (mm)
32	S	180	8	4,5	70	35	19	42,4	3	50
40	S	200	11	7	49	21	26	48,3	3	50
50	L	205	19	10	49	30	39	60,3	4	50
	S	156	10	3	92	189				
65	L	216	23	11	49	38	58	76,1	4	50
	S	180	16	5	71	112				
80	L	210	24	9	52	60	80	88,9	4	50
	S	174	17	4	75	181				
100	L	265	32	12	67	74	129	114,3	4	60
	S	210	25	6	49	132				
125	L	266	32	10	78	121	187	139,7	4	60
	S	194	20	3,5	73	404				
150	L	264	38	10	63	143	271	168,3	5	60
	S	196	20	3	115	879				
200	L	290	45	11,5	93	250	452	219,1	5	60
	S	210	28	3,5	102	895				
250	L	350	48	11	96	317	684	273	5	80
	S	250	30	3	104	1.380				
300	L	370	55	11,5	99	369	945	323,9	6	80
	S	270	32	3,5	159	1.984				
350	L	410	58	11	95	422	1.133	355,6	6	100
	S	310	32	3,5	170	2.533				
400	L	400	58	9,5	97	604	1.478	406,4	6	100
	S	320	38	4	139	2.257				
450	L	420	60	10	105	681	1.839	457,2	6	100
	S	320	36	3	170	3.419				
500	L	420	65	10	93	743	2.263	508	6	100
	S	320	35	3	167	4.132				

Please consult with our technical department for different working conditions and design parameters.

Movements are non-concurrent



## DESIGN VALUES

Bellows Material	304, 316, 321
Weld End Material	Carbon Steel, Stainless Steel
Design Pressure	10 barg
Design Temperature	400°C

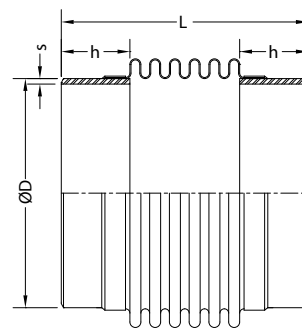

# PN 10

DN	Type	Length (L) (mm)	Movements		Spring Rates		Effective Area (cm <sup>2</sup> )	Weld-End		
			Axial (+/-) (mm)	Lateral (+/-) (mm)	Axial (N/mm)	Lateral (N/mm)		ØD (mm)	s (mm)	h (mm)
32	S	180	8	4,5	64	33	19	42,4	3	50
40	S	180	9	4,5	57	37	26	48,3	3	50
50	S	180	15	6	61	64	39	60,3	4	50
65	S	190	17	6	64	81	58	76,1	4	50
80	L	234	22	10	94	74	80	88,9	4	50
	S	184	18	5,5	65	125				
100	L	240	24	7,5	89	139	129	114,3	5	60
	S	190	18	3,5	71	300				
125	L	250	26	7,5	99	190	187	139,7	5	60
	S	190	18	3	81	495				
150	L	250	27	6,5	100	271	271	168,3	5	60
	S	210	22	3,5	79	423				
200	L	270	35	8	116	396	452	219,1	5	60
	S	210	23	3	131	1.133				
250	L	330	40	8	122	494	684	273	6	80
	S	250	23	2,5	192	2.562				
300	L	340	44	8	126	624	945	323,9	6	80
	S	270	27	3	202	2.489				
350	L	390	45	7,5	158	859	1.133	355,6	6	100
	S	310	28	2,5	253	3.793				
400	L	400	50	8	152	954	1.478	406,4	8	100
	S	320	30	3	256	4.136				
450	L	430	50	8,5	165	991	1.839	457,2	8	100
	S	320	30	2,5	283	5.703				
500	L	430	50	7,5	191	1.393	2.263	508	8	100
	S	320	27	2	343	8.426				

Please consult with our technical department for different working conditions and design parameters.

Movements are non-concurrent

## DESIGN VALUES

Bellows Material	304, 316, 321
Weld End Material	Carbon Steel, Stainless Steel
Design Pressure	16 barg
Design Temperature	400°C

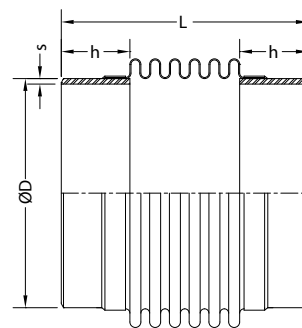

# PN 16

DN	Type	Length (L) (mm)	Movements		Spring Rates		Effective Area (cm <sup>2</sup> )	Weld-End		
			Axial (+/-) (mm)	Lateral (+/-) (mm)	Axial (N/mm)	Lateral (N/mm)		ØD (mm)	s (mm)	h (mm)
32	S	170	7	3,5	76	50	19	42,4	3	50
40	S	164	7	2,5	74	73	26	48,3	3	50
50	S	170	12	4	79	105	39	60,3	4	50
65	S	170	13	3,5	80	163	58	76,1	4	50
80	L	210	17	6,5	125	143	80	88,9	4	50
	S	160	12	2,5	99	353				
100	L	254	22	7,5	146	186	129	114,3	5	60
	S	220	19	5	113	249				
125	L	270	23	7,5	164	241	187	139,7	5	60
	S	220	21	4,5	114	363				
150	L	270	23	6,5	170	352	271	168,3	5	60
	S	200	15	2	180	1.217				
200	L	294	31	8	195	499	452	219,1	5	60
	S	210	18	2,5	255	2.208				
250	L	340	32	6,5	201	731	684	273	6	80
	S	250	18	2	343	4.557				
300	L	380	40	8,5	262	912	945	323,9	6	80
	S	280	22	2,5	472	5.103				
350	L	440	43	9	264	925	1.133	355,6	6	100
	S	320	22	2,5	513	6.592				
400	L	430	43	8	288	1.395	1.478	406,4	8	100
	S	324	24	2,5	519	7.948				
450	L	460	45	8,5	302	1.441	1.839	457,2	8	100
	S	324	22	2	604	11.529				
500	L	580	52	13	429	1.208	2.263	508	8	100
	S	360	23	2	1001	14.638				

Please consult with our technical department for different working conditions and design parameters.

Movements are non-concurrent

## DESIGN VALUES

Bellows Material	304, 316, 321
Weld End Material	Carbon Steel, Stainless Steel
Design Pressure	25 barg
Design Temperature	400°C

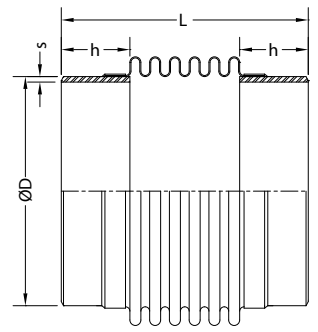

# PN 25

DN	Type	Length (L) (mm)	Movements		Spring Rates		Effective Area (cm <sup>2</sup> )	Weld-End		
			Axial (+/-) (mm)	Lateral (+/-) (mm)	Axial (N/mm)	Lateral (N/mm)		ØD (mm)	s (mm)	h (mm)
50	S	155	9	2,5	102	215	39	60,3	4	50
65	S	155	9	2	129	402	58	76,1	4	50
80	L	180	12	3	161	340	80	88,9	4	50
	S	155	8	1,5	226	955				
100	L	250	16	6	221	289	129	114,3	4	60
	S	200	11	2,5	276	923				
125	L	250	16	5	243	460	187	139,7	6	60
	S	200	11	2	326	1.569				
150	L	250	20	5	227	608	271	168,3	6	60
	S	215	15	3	263	1.284				
200	L	250	23	4,5	290	1.290	452	219,1	8	60
	S	225	19	3	354	2.348				
250	L	320	29	5,5	344	1.572	684	273	8	80
	S	270	20	2,5	6204	4.279				
300	L	340	32	5,5	507	2.588	975	323,9	8	80
	S	280	21	2,5	530	5.711				
350	L	400	36	6,5	480	1.391	1.161	355,6	8	100
	S	325	17	2	1199	14.065				
400	L	390	34	5	556	3.874	1.489	406,4	10	100
	S	330	24	2,5	778	10.975				
450	L	400	35	5	819	6.488	1.865	457,2	10	100
	S	340	22	2	992	15.450				
500	L	400	37	5	776	7.539	2.290	508	10	100
	S	340	25	2,5	1138	21.480				

Please consult with our technical department for different working conditions and design parameters.

Movements are non-concurrent

# FLOATING FLANGED

## Expansion Joints

Floating flanged expansion joints are equipped with carbon steel or stainless steel flanges (EN, ASME or as requested). It absorbs mainly axial movements with possibility of some lateral movements.

Even though they can absorb movements in any direction, this type is mainly used for axial movements. If lateral movement is requested, a universal type may be more suitable. These type of expansion joints can be supplied with limit rod, liners, covers, rods, hinges or gimbals.

Available for exhaust gas, liquid medium and steam. Bellows are calculated following latest EJMA standards.

Also, floating flange type expansion joints may have a double bellows which are designed for absorbing the higher lateral movements.

### Advantages

- » Quick connection
- » Easy installation for existing systems
- » Easily replaced
- » Flanges are not in direct contact with media due to bellows
- » Flange misalignment with customer's flange is prevented

### Applications

- » Hot & Cold water pipelines
- » District heating pipelines
- » Steam pipelines
- » Shipbuilding and exhaust systems
- » Geothermal water applications
- » Process based fluids

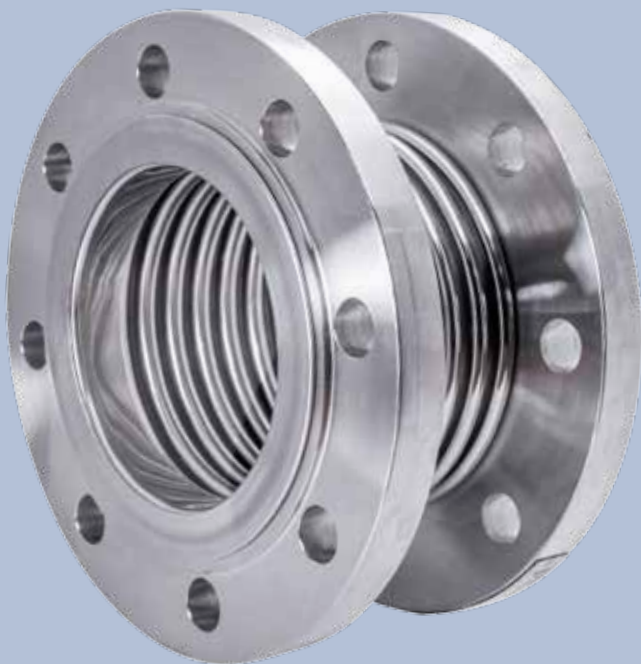

# DESIGN VALUES

Bellows Material	304, 316, 321
Flange Material	Carbon Steel, Stainless Steel
Flange Norms	EN 1092, ANSI B16.5, JIS
Design Pressure	2.5 barg
Design Temperature	550°C

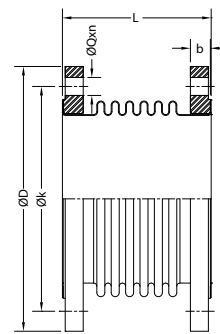

# PN 2,5

DN	Type	Length (L) (mm)	Movements		Spring Rates		Effective Area (cm <sup>2</sup> )	PN 2,5				
			Axial (+/-) (mm)	Lateral (+/-) (mm)	Axial (N/mm)	Lateral (N/mm)		ØD (mm)	Øk (mm)	b (mm)	n	ØQ (mm)
32	L	210	16	17	31	4	18	120	90	14	4	14
	S	140	8	5	57	26						
40	L	210	18	17	27	5	23	130	100	14	4	14
	S	140	10	5	50	29						
50	L	210	29	22	30	9	37	140	110	14	4	14
	S	160	20	10	44	27						
65	L	215	33	21	32	13	58	160	130	14	4	14
	S	160	22	9	48	45						
80	L	240	40	22	27	14	79	190	150	16	4	18
	S	180	24	9	46	58						
100	L	250	35	16	60	45	128	210	170	16	4	18
	S	180	23	6	82	166						
125	L	265	36	15	67	66	187	240	200	18	8	18
	S	195	26	7	85	202						
150	L	270	50	17	44	62	271	265	225	18	8	18
	S	195	30	6	65	274						
200	L	300	64	19	41	78	460	320	280	20	8	18
	S	200	40	6	58	389						
250	L	305	70	16	42	42	688	375	335	22	12	18
	S	205	40	5	68	683						
300	L	325	70	16	50	161	945	440	395	22	12	22
	S	205	40	4	78	1.076						
350	L	330	65	16	47	181	1.127	490	445	22	12	22
	S	200	35	3	102	1.993						
400	L	330	65	14	51	255	1.478	540	495	22	16	22
	S	205	30	2	65	1.507						
450	L	330	70	13	51	329	1.839	595	550	22	16	22
	S	210	35	2	80	2.001						
500	L	330	85	13	44	354	2.263	645	600	24	20	22
	S	225	40	2	72	1931						

Please consult with our technical department for different working conditions and design parameters.

Movements are non-concurrent

# DESIGN VALUES

Bellows Material	304, 316, 321
Flange Material	Carbon Steel, Stainless Steel
Flange Norms	EN 1092, ANSI B16.5, JIS
Design Pressure	6 barg
Design Temperature	400°C

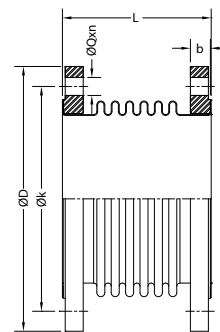

# PN 6

DN	Type	Length (L) (mm)	Movements		Spring Rates		Effective Area (cm <sup>2</sup> )	PN 6				
			Axial (+/-) (mm)	Lateral (+/-) (mm)	Axial (N/mm)	Lateral (N/mm)		ØD (mm)	Øk (mm)	b (mm)	n	ØQ (mm)
25	S	115	8	4,5	70	35	19	100	75	14	4	11
32	S	115	8	4,5	70	35	19	120	90	14	4	14
40	S	135	11	7	49	21	26	130	100	14	4	14
50	L	140	19	10	49	30	39	140	110	14	4	14
	S	90	10	3	92	189	39	140	110	14	4	14
65	L	155	23	11	49	38	58	160	130	14	4	14
	S	120	16	5	71	112	58	160	130	14	4	14
80	L	155	24	9	52	60	79	190	150	16	4	18
	S	120	17	4	75	181	79	190	150	16	4	18
100	L	225	32	12	67	74	130	210	170	16	4	18
	S	170	25	6	49	132	129	210	170	16	4	18
125	L	230	32	10	78	121	188	240	200	18	8	18
	S	160	20	3,5	73	404	187	240	200	18	8	18
150	L	230	38	10	63	143	271	265	225	18	8	18
	S	160	20	3	115	879	271	265	225	18	8	18
200	L	280	45	11,5	93	250	452	320	280	20	8	18
	S	200	28	3,5	102	895	452	320	280	20	8	18
250	L	300	48	11	96	317	684	375	335	22	12	18
	S	200	30	3	104	1.380	684	375	335	22	12	18
300	L	325	55	11,5	99	369	951	440	395	22	12	22
	S	225	32	3,5	159	1.984	956	440	395	22	12	22
350	L	325	58	11	95	422	1.142	490	445	22	12	22
	S	225	32	3,5	170	2.533	1.142	490	445	22	12	22
400	L	315	58	9,5	97	604	1.472	540	495	22	16	22
	S	235	38	4	139	2.257	1.479	540	495	22	16	22
450	L	335	60	10	105	681	1.832	595	550	22	16	22
	S	235	36	3	170	3.419	1.840	595	550	22	16	22
500	L	340	65	10	93	743	2.258	645	600	24	20	22
	S	240	35	3	167	4.132	2.258	645	600	24	20	22

Please consult with our technical department for different working conditions and design parameters.

Movements are non-concurrent

# DESIGN VALUES

Bellows Material	304, 316, 321
Flange Material	Carbon Steel, Stainless Steel
Flange Norms	EN 1092, ANSI B16.5, JIS
Design Pressure	10 barg
Design Temperature	400°C

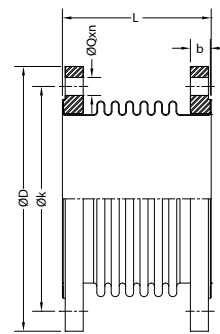

# PN 10

DN	Type	Length (L) (mm)	Movements		Spring Rates		Effective Area (cm <sup>2</sup> )	PN 10				
			Axial (+/-) (mm)	Lateral (+/-) (mm)	Axial (N/mm)	Lateral (N/mm)		ØD (mm)	Øk (mm)	b (mm)	n	ØQ (mm)
25	S	125	8	4,5	64	33	19	115	85	18	4	14
32	S	125	8	4,5	64	33	19	140	100	18	4	18
40	S	125	9	4,5	57	37	26	150	110	18	4	18
50	S	125	15	6	61	64	39	165	125	18	4	18
65	S	140	17	6	64	81	58	185	145	18	8	18
80	L	190	22	10	94	74	80	200	160	20	8	18
	S	140	18	5,5	65	125	79	200	160	20	8	18
100	L	180	24	7,5	89	139	130	220	180	20	8	18
	S	125	18	3,5	71	300	129	220	180	20	8	18
125	L	190	26	7,5	99	190	187	250	210	22	8	18
	S	130	18	3	81	495	187	250	210	22	8	18
150	L	190	27	6,5	100	271	264	285	240	22	8	22
	S	150	22	3,5	79	423	259	285	240	22	8	22
200	L	255	35	8	116	396	452	340	295	24	8	22
	S	195	23	3	131	1.133	445	340	295	24	8	22
250	L	285	40	8	122	494	679	395	350	26	12	22
	S	205	23	2,5	192	2.562	684	395	350	26	12	22
300	L	300	44	8	126	624	948	445	400	26	12	22
	S	230	27	3	202	2.489	948	445	400	26	12	22
350	L	270	45	7,5	158	859	1.148	505	460	26	16	22
	S	190	28	2,5	253	3.793	1.148	505	460	26	16	22
400	L	280	50	8	152	954	1.477	565	515	26	16	26
	S	200	30	3	256	4.136	1.477	565	515	26	16	26
450	L	310	50	8,5	165	991	1.838	615	565	28	20	26
	S	200	30	2,5	283	5.703	1.845	615	565	28	20	26
500	L	310	50	7,5	191	1.393	2.245	670	620	28	20	26
	S	200	27	2	343	8.426	2.245	670	620	28	20	26
450	L	335	60	10	105	681	1.832	595	550	22	16	22
	S	235	36	3	170	3.419	1.840	595	550	22	16	22
500	L	340	65	10	93	743	2.258	645	600	24	20	22
	S	240	35	3	167	4.132	2.258	645	600	24	20	22

Please consult with our technical department for different working conditions and design parameters.  
Movements are non-concurrent

# DESIGN VALUES

Bellows Material	304, 316, 321
Flange Material	Carbon Steel, Stainless Steel
Flange Norms	EN 1092, ANSI B16.5, JIS
Design Pressure	16 barg
Design Temperature	400°C

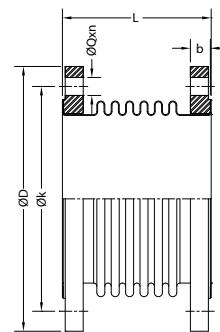

# PN 16

DN	Type	Length (L) (mm)	Movements		Spring Rates		Effective Area (cm <sup>2</sup> )	PN 16				
			Axial (+/-) (mm)	Lateral (+/-) (mm)	Axial (N/mm)	Lateral (N/mm)		ØD (mm)	Øk (mm)	b (mm)	n	ØQ (mm)
25	S	115	7	3,5	76	50	19	115	85	18	4	14
32	S	115	7	3,5	76	50	18	140	100	18	4	18
40	S	115	7	2,5	74	73	26	150	110	18	4	18
50	S	115	12	4	79	105	39	165	125	18	4	18
65	S	120	13	3,5	80	163	58	185	145	18	4	18
80	L	165	17	6,5	125	143	79	200	160	20	8	18
	S	120	12	2,5	99	353	79	200	160	20	8	18
100	L	190	22	7,5	146	186	130	220	180	20	8	18
	S	160	19	5	113	249	129	220	180	20	8	18
125	L	210	23	7,5	164	241	187	250	210	22	8	18
	S	160	21	4,5	114	363	188	250	210	22	8	18
150	L	210	23	6,5	170	352	263	285	240	22	8	22
	S	140	15	2	180	1.217	264	285	240	22	8	22
200	L	280	31	8	195	499	452	340	295	24	12	22
	S	200	18	2,5	255	2.208	445	340	295	24	12	22
250	L	310	32	6,5	201	731	680	405	355	26	12	26
	S	220	18	2	343	4.557	684	405	355	26	12	26
300	L	370	40	8,5	262	912	974	460	410	28	12	26
	S	270	22	2,5	472	5.103	972	460	410	28	12	26
350	L	330	43	9	264	925	1.155	520	470	30	16	26
	S	210	22	2,5	513	6.592	1.156	520	470	30	16	26
400	L	330	43	8	288	1.395	1.484	580	525	32	16	30
	S	220	24	2,5	519	7.948	1.484	580	525	32	16	30
450	L	360	45	8,5	302	1.441	1.849	640	585	34	20	30
	S	220	22	2	604	11.529	1.851	640	585	34	20	30
500	L	480	52	13	429	1.208	2.265	715	650	36	20	33
	S	260	23	2	1001	14.638	2.265	715	650	36	20	33

Please consult with our technical department for different working conditions and design parameters.

Movements are non-concurrent



## DESIGN VALUES

Bellows Material	304, 316, 321
Flange Material	Carbon Steel, Stainless Steel
Flange Norms	EN 1092, ANSI B16.5, JIS
Design Pressure	25 barg
Design Temperature	400°C

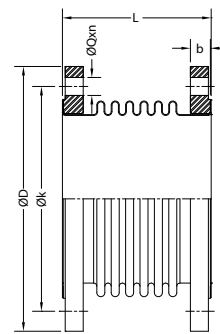

# PN 25

DN	Type	Length (L) (mm)	Movements		Spring Rates		Effective Area (cm <sup>2</sup> )	PN 25				
			Axial (+/-) (mm)	Lateral (+/-) (mm)	Axial (N/mm)	Lateral (N/mm)		ØD (mm)	Øk (mm)	b (mm)	n	ØQ (mm)
50	S	105	9	2,5	102	215	38	165	125	20	4	18
65	S	105	9	2	129	402	57	185	145	22	8	18
80	L	135	12	3	161	340	90	200	160	24	8	18
	S	110	8	1,5	226	955	77	200	160	24	8	18
100	L	185	16	6	221	289	129	235	190	24	8	22
	S	135	11	2,5	276	923	129	235	190	24	8	22
125	L	190	16	5	243	460	187	270	220	26	8	26
	S	140	11	2	326	1.569	187	270	220	26	8	26
150	L	195	20	5	227	608	258	300	250	28	8	26
	S	160	15	3	263	1.284	258	300	250	28	8	26
200	L	200	23	4,5	290	1.290	444	360	310	30	12	26
	S	175	19	3	354	2.348	444	360	310	30	12	26
250	L	235	29	5,5	344	1.572	682	425	370	32	12	30
	S	185	20	2,5	6204	4.279	682	425	370	32	12	30
300	L	260	32	5,5	507	2.588	975	485	430	34	16	30
	S	200	21	2,5	530	5.711	975	485	430	34	16	30
350	L	290	36	6,5	480	1.391	1.161	555	490	38	16	33
	S	215	17	2	1199	14.065	1.161	555	490	38	16	33
400	L	285	34	5	556	3.874	1.489	620	550	40	16	36
	S	225	24	2,5	778	10.975	1.489	620	550	40	16	36
450	L	305	35	5	819	6.488	1.865	670	600	46	20	36
	S	245	22	2	992	15.450	1.865	670	600	46	20	36
500	L	310	37	5	776	7.539	2.289	730	660	48	20	36
	S	250	25	2,5	1138	21.480	2.289	730	660	48	20	36

Please consult with our technical department for different working conditions and design parameters.

Movements are non-concurrent

# FIXED FLANGED

## Expansion Joints

Fixed flanged expansion joints are equipped with welded carbon steel or stainless steel flanges (EN, ASME or as requested). It absorbs mainly axial movements with possibility of some lateral movements.

Even though they can absorb movements in any direction, this type is mainly used for axial movements. If lateral movement is requested, a universal type may be more suitable. These type of expansion joints can be supplied with limit rod, liners, covers, rods, hinges or gimbals.

Available for exhaust gas, liquid medium and steam. Bellows are calculated following latest EJMA standards.

Also, fixed flanged type expansion joints may have a double bellows which are designed for absorbing the higher lateral movements.

### Advantages

- » Quick connection
- » Easy installation
- » Can be used at higher pressures than floating flanged expansion joints
- » Easily replaced

### Applications

- » Hot & Cold water pipelines
- » District heating pipelines
- » Steam pipelines
- » Shipbuilding and exhaust systems
- » Geothermal water applications
- » Process based fluids



# DESIGN VALUES

Bellows Material	304, 316, 321
Flange Material	Carbon Steel, Stainless Steel
Flange Norms	EN 1092, ANSI B16.5, JIS
Design Pressure	2,5 barg
Design Temperature	550°C

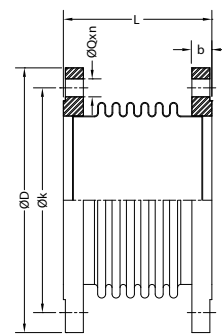

# PN 2,5

DN	Type	Length (L) (mm)	Movements		Spring Rates		Effective Area (cm <sup>2</sup> )	PN 2,5				
			Axial (+/-) (mm)	Lateral (+/-) (mm)	Axial (N/mm)	Lateral (N/mm)		ØD (mm)	Øk (mm)	b (mm)	n	ØQ (mm)
32	L	210	16	17	31	4	18	120	90	14	4	14
	S	140	8	5	57	26						
40	L	210	18	17	27	5	23	130	100	14	4	14
	S	140	10	5	50	29						
50	L	210	29	22	30	9	37	140	110	14	4	14
	S	160	20	10	44	27						
65	L	215	33	21	32	13	58	160	130	14	4	14
	S	160	22	9	48	45						
80	L	240	40	22	27	14	79	190	150	16	4	18
	S	180	24	9	46	58						
100	L	250	35	16	60	45	128	210	170	16	4	18
	S	180	23	6	82	166						
125	L	265	36	15	67	66	187	240	200	18	8	18
	S	195	26	7	85	202						
150	L	270	50	17	44	62	271	265	225	18	8	18
	S	195	30	6	65	274						
200	L	300	64	19	41	78	460	320	280	20	8	18
	S	200	40	6	58	389						
250	L	305	70	16	42	42	688	375	335	22	12	18
	S	205	40	5	68	683						
300	L	325	70	16	50	161	945	440	395	22	12	22
	S	205	40	4	78	1.076						
350	L	330	65	16	47	181	1.127	490	445	22	12	22
	S	200	35	3	102	1.993						
400	L	330	65	14	51	255	1.478	540	495	22	16	22
	S	205	30	2	65	1.507						
450	L	330	70	13	51	329	1.839	595	550	22	16	22
	S	210	35	2	80	2.001						
500	L	330	85	13	44	354	2.263	645	600	24	20	22
	S	225	40	2	72	1931						

Please consult with our technical department for different working conditions and design parameters.

Movements are non-concurrent

# DESIGN VALUES

Bellows Material	304, 316, 321
Flange Material	Carbon Steel, Stainless Steel
Flange Norms	EN 1092, ANSI B16.5, JIS
Design Pressure	6 barg
Design Temperature	400°C

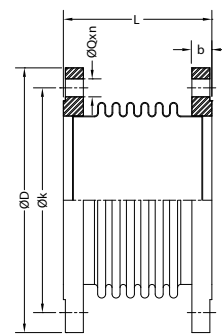

# PN 6

DN	Type	Length (L) (mm)	Movements		Spring Rates		Effective Area (cm <sup>2</sup> )	PN 6				
			Axial (+/-) (mm)	Lateral (+/-) (mm)	Axial (N/mm)	Lateral (N/mm)		ØD (mm)	Øk (mm)	b (mm)	n	ØQ (mm)
25	S	115	8	4,5	70	35	19	100	75	14	4	11
32	S	115	8	4,5	70	35	19	120	90	14	4	14
40	S	135	11	7	49	21	26	130	100	14	4	14
50	L	140	19	10	49	30	39	140	110	14	4	14
	S	90	10	3	92	189	39	140	110	14	4	14
65	L	155	23	11	49	38	58	160	130	14	4	14
	S	120	16	5	71	112	58	160	130	14	4	14
80	L	155	24	9	52	60	79	190	150	16	4	18
	S	120	17	4	75	181	79	190	150	16	4	18
100	L	225	32	12	67	74	130	210	170	16	4	18
	S	170	25	6	49	132	129	210	170	16	4	18
125	L	230	32	10	78	121	188	240	200	18	8	18
	S	160	20	3,5	73	404	187	240	200	18	8	18
150	L	230	38	10	63	143	271	265	225	18	8	18
	S	160	20	3	115	879	271	265	225	18	8	18
200	L	280	45	11,5	93	250	452	320	280	20	8	18
	S	200	28	3,5	102	895	452	320	280	20	8	18
250	L	300	48	11	96	317	684	375	335	22	12	18
	S	200	30	3	104	1.380	684	375	335	22	12	18
300	L	325	55	11,5	99	369	951	440	395	22	12	22
	S	225	32	3,5	159	1.984	956	440	395	22	12	22
350	L	325	58	11	95	422	1.142	490	445	22	12	22
	S	225	32	3,5	170	2.533	1.142	490	445	22	12	22
400	L	315	58	9,5	97	604	1.472	540	495	22	16	22
	S	235	38	4	139	2.257	1.479	540	495	22	16	22
450	L	335	60	10	105	681	1.832	595	550	22	16	22
	S	235	36	3	170	3.419	1.840	595	550	22	16	22
500	L	340	65	10	93	743	2.258	645	600	24	20	22
	S	240	35	3	167	4.132	2.258	645	600	24	20	22

Please consult with our technical department for different working conditions and design parameters.

Movements are non-concurrent

# DESIGN VALUES

Bellows Material	304, 316, 321
Flange Material	Carbon Steel, Stainless Steel
Flange Norms	EN 1092, ANSI B16.5, JIS
Design Pressure	10 barg
Design Temperature	400°C

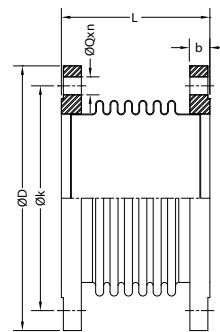

# PN 10

DN	Type	Length (L) (mm)	Movements		Spring Rates		Effective Area (cm <sup>2</sup> )	PN 10				
			Axial (+/-) (mm)	Lateral (+/-) (mm)	Axial (N/mm)	Lateral (N/mm)		ØD (mm)	Øk (mm)	b (mm)	n	ØQ (mm)
25	S	125	8	4,5	64	33	19	115	85	18	4	14
32	S	125	8	4,5	64	33	19	140	100	18	4	18
40	S	125	9	4,5	57	37	26	150	110	18	4	18
50	S	125	15	6	61	64	39	165	125	18	4	18
65	S	140	17	6	64	81	58	185	145	18	8	18
80	L	190	22	10	94	74	80	200	160	20	8	18
	S	140	18	5,5	65	125	79	200	160	20	8	18
100	L	180	24	7,5	89	139	130	220	180	20	8	18
	S	125	18	3,5	71	300	129	220	180	20	8	18
125	L	190	26	7,5	99	190	187	250	210	22	8	18
	S	130	18	3	81	495	187	250	210	22	8	18
150	L	190	27	6,5	100	271	264	285	240	22	8	22
	S	150	22	3,5	79	423	259	285	240	22	8	22
200	L	255	35	8	116	396	452	340	295	24	8	22
	S	195	23	3	131	1.133	445	340	295	24	8	22
250	L	285	40	8	122	494	679	395	350	26	12	22
	S	205	23	2,5	192	2.562	684	395	350	26	12	22
300	L	300	44	8	126	624	948	445	400	26	12	22
	S	230	27	3	202	2.489	948	445	400	26	12	22
350	L	270	45	7,5	158	859	1.148	505	460	26	16	22
	S	190	28	2,5	253	3.793	1.148	505	460	26	16	22
400	L	280	50	8	152	954	1.477	565	515	26	16	26
	S	200	30	3	256	4.136	1.477	565	515	26	16	26
450	L	310	50	8,5	165	991	1.838	615	565	28	20	26
	S	200	30	2,5	283	5.703	1.845	615	565	28	20	26
500	L	310	50	7,5	191	1.393	2.245	670	620	28	20	26
	S	200	27	2	343	8.426	2.245	670	620	28	20	26
450	L	335	60	10	105	681	1.832	595	550	22	16	22
	S	235	36	3	170	3.419	1.840	595	550	22	16	22
500	L	340	65	10	93	743	2.258	645	600	24	20	22
	S	240	35	3	167	4.132	2.258	645	600	24	20	22

Please consult with our technical department for different working conditions and design parameters.  
Movements are non-concurrent

# DESIGN VALUES

Bellows Material	304, 316, 321
Flange Material	Carbon Steel, Stainless Steel
Flange Norms	EN 1092, ANSI B16.5, JIS
Design Pressure	16 barg
Design Temperature	400°C

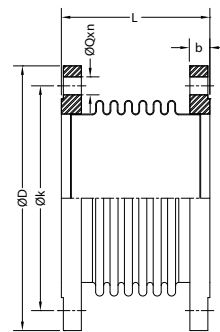

# PN 16

DN	Type	Length (L) (mm)	Movements		Spring Rates		Effective Area (cm <sup>2</sup> )	PN 16				
			Axial (+/-) (mm)	Lateral (+/-) (mm)	Axial (N/mm)	Lateral (N/mm)		ØD (mm)	Øk (mm)	b (mm)	n	ØQ (mm)
25	S	115	7	3,5	76	50	19	115	85	18	4	14
32	S	115	7	3,5	76	50	18	140	100	18	4	18
40	S	115	7	2,5	74	73	26	150	110	18	4	18
50	S	115	12	4	79	105	39	165	125	18	4	18
65	S	120	13	3,5	80	163	58	185	145	18	4	18
80	L	165	17	6,5	125	143	79	200	160	20	8	18
	S	120	12	2,5	99	353	79	200	160	20	8	18
100	L	190	22	7,5	146	186	130	220	180	20	8	18
	S	160	19	5	113	249	129	220	180	20	8	18
125	L	210	23	7,5	164	241	187	250	210	22	8	18
	S	160	21	4,5	114	363	188	250	210	22	8	18
150	L	210	23	6,5	170	352	263	285	240	22	8	22
	S	140	15	2	180	1.217	264	285	240	22	8	22
200	L	280	31	8	195	499	452	340	295	24	12	22
	S	200	18	2,5	255	2.208	445	340	295	24	12	22
250	L	310	32	6,5	201	731	680	405	355	26	12	26
	S	220	18	2	343	4.557	684	405	355	26	12	26
300	L	370	40	8,5	262	912	974	460	410	28	12	26
	S	270	22	2,5	472	5.103	972	460	410	28	12	26
350	L	330	43	9	264	925	1.155	520	470	30	16	26
	S	210	22	2,5	513	6.592	1.156	520	470	30	16	26
400	L	330	43	8	288	1.395	1.484	580	525	32	16	30
	S	220	24	2,5	519	7.948	1.484	580	525	32	16	30
450	L	360	45	8,5	302	1.441	1.849	640	585	34	20	30
	S	220	22	2	604	11.529	1.851	640	585	34	20	30
500	L	480	52	13	429	1.208	2.265	715	650	36	20	33
	S	260	23	2	1001	14.638	2.265	715	650	36	20	33

Please consult with our technical department for different working conditions and design parameters.

Movements are non-concurrent

## DESIGN VALUES

Bellows Material	304, 316, 321
Flange Material	Carbon Steel, Stainless Steel
Flange Norms	EN 1092, ANSI B16.5, JIS
Design Pressure	25 barg
Design Temperature	400°C

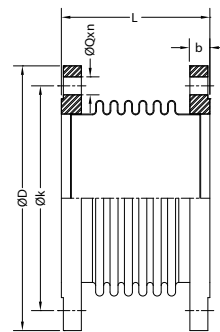

# PN 25

DN	Type	Length (L) (mm)	Movements		Spring Rates		Effective Area (cm <sup>2</sup> )	PN 25				
			Axial (+/-) (mm)	Lateral (+/-) (mm)	Axial (N/mm)	Lateral (N/mm)		ØD (mm)	Øk (mm)	b (mm)	n	ØQ (mm)
50	S	105	9	2,5	102	215	38	165	125	20	4	18
65	S	105	9	2	129	402	57	185	145	22	8	18
80	L	135	12	3	161	340	90	200	160	24	8	18
	S	110	8	1,5	226	955	77	200	160	24	8	18
100	L	185	16	6	221	289	129	235	190	24	8	22
	S	135	11	2,5	276	923	129	235	190	24	8	22
125	L	190	16	5	243	460	187	270	220	26	8	26
	S	140	11	2	326	1.569	187	270	220	26	8	26
150	L	195	20	5	227	608	258	300	250	28	8	26
	S	160	15	3	263	1.284	258	300	250	28	8	26
200	L	200	23	4,5	290	1.290	444	360	310	30	12	26
	S	175	19	3	354	2.348	444	360	310	30	12	26
250	L	235	29	5,5	344	1.572	682	425	370	32	12	30
	S	185	20	2,5	6204	4.279	682	425	370	32	12	30
300	L	260	32	5,5	507	2.588	975	485	430	34	16	30
	S	200	21	2,5	530	5.711	975	485	430	34	16	30
350	L	290	36	6,5	480	1.391	1.161	555	490	38	16	33
	S	215	17	2	1199	14.065	1.161	555	490	38	16	33
400	L	285	34	5	556	3.874	1.489	620	550	40	16	36
	S	225	24	2,5	778	10.975	1.489	620	550	40	16	36
450	L	305	35	5	819	6.488	1.865	670	600	46	20	36
	S	245	22	2	992	15.450	1.865	670	600	46	20	36
500	L	310	37	5	776	7.539	2.289	730	660	48	20	36
	S	250	25	2,5	1138	21.480	2.289	730	660	48	20	36

Please consult with our technical department for different working conditions and design parameters.

Movements are non-concurrent

# RUBBER

## Expansion Joints

In order to offer a complete product range for our customers, we also supply rubber expansion joints.

Rubber expansion joints are flexible units that are manufactured from natural or synthetic elastomers or fluoroplastics. If necessary, a reinforcement of the bellow (steel, nylon or aramid) may be added. Rubber expansion joints are the perfect solution for pipe systems to absorb movements, vibrations or noise, resulting in the significantly prolonged service life of the pipe work and connected equipment.



## Advantages

- » Best solution to vibration, noise and misalignment problems
- » Up to 16 barg pressure and 110°C temperature working conditions
- » Rubber body with Nylon-Cord carcassed
- » Flanged construction with integral self-sealing profile
- » Flanges are electro galvanized carbon steel material
- » Minimal face to face dimensions
- » Lightweight
- » Low spring rates
- » Flanges with limit rod connections or limit rod kits are available
- » Optimum solution for narrow spaces, still able to absorb large movements due to the flexible body
- » Absorb axial, lateral, and angular movements
- » Safe, reliable, durable and maintenance free
- » Temperature, chemical, and corrosion resistant
- » Acoustical impedance
- » Greater shock resistance
- » No gaskets required
- » Can accommodate line misalignment

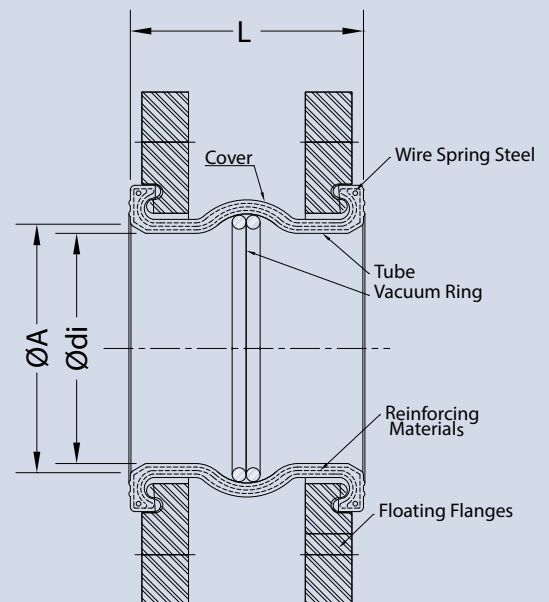



## DESIGN VALUES

Body Material	EPDM, NBR, CR, SBR
Flange Material	Carbon Steel, Ductile Iron, Stainless Steel
Flange Norms	EN 1092, ANSI B16.5
Design Pressure	16 barg
Design Temperature	110°C

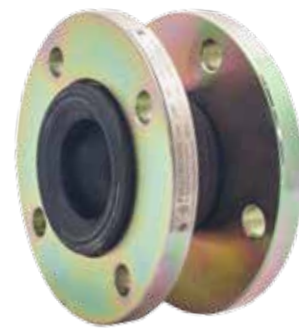

## Applications

- » Power plants
- » Pumps
- » Off-shore applications
- » Sanitary piping systems
- » Slurry water pipelines
- » Cooling and chiller systems
- » Chemical plants
- » Shipbuilding pipelines and machine room pump stations
- » Water treatment plants
- » Sewage pipelines
- » Oil & gas plants
- » Pulp and paper plants
- » Absorption Chiller units
- » Desalination units
- » Heating, ventilating and air conditioning systems

## Flanges

Carbon steel and cast iron are used as standard. Flanges are also available in zinc plated or HDG carbon steel, stainless steel or etc. Flanges are drilled to EN 1092, ANSI B16.5, JIS, AWWA standards or any specific dimension.

## Body Material

### EPDM

- » Good heat resistance
- » Suitable for alkaline waste water
- » Suitable for some chemical compounds except hydrocarbons
- » Not suitable for oils or fatty media

### NBR

- » Oil and Fuel applications
- » Suitable for solvent and fats
- » Not suitable for hot water

### CR

- » Suitable for some small groups of lyes and alkaline and acid salt solution.
- » Weather-resistant
- » Resistance to some chemicals

### SBR

- » Good resistance to abrasive fluids
- » Highest mechanical properties
- » Good mechanical strength to sludge suspended stones, calcium, etc.

Tube	Common Name	Reinforcing	Cover	Bellows Colour	Temperature Range	Permissible Operating Data			Hardness	Burst Pressure
EPDM	EPDM	Nylon Cord C.	EPDM	Red Point	-35 / +110 °C	16barg@50°C	10barg@70°C	6barg@90°C		
NBR	Nitrile	Nylon Cord C.	EPDM	Yellow Point	-30 / +80 °C	16barg@30°C	10barg@50°C	6barg@70°C	60 ShoreA	45 barg
CR	Neoprene	Nylon Cord C.	EPDM	Blue Point	-30/ +70 °C	16barg@30°C	10barg@50°C	6barg@70°C		

# RUBBER

## Expansion Joints

DN		L (Tolerance $\pm 5$ mm)			Face of Bellows (Tolerance $\pm 3$ mm)			Flange	Permissible Movements			
		Type A	Type B	Type C	$\varnothing$ di	$\varnothing$ A	$\varnothing$ E	Thickness	Compression	Extension	Lateral	Angular
		mm	mm	mm	mm	mm	mm	mm	mm	mm	mm	deg.
25	1"	100	130	170	30	37	61	14	20	10	10	25
32	1 1/4"	100	130	150	37	51	75,5	14	20	10	10	25
40	1 1/2"	100	130	150	37	51	75,5	14	20	10	10	25
50	2"	100	130	150	50	60	86,5	15	20	10	10	25
65	2 1/2"	100	130	150	62	76	100	15	20	10	10	20
80	3"	100	130	150	78	91	117	17	20	10	10	20
100	4"	100	130	150	100	112	139	17	20	10	10	15
125	5"	120	130	150	124	136	167	19	25	15	15	15
150	6"	120	130	150	150	161	197,5	19	25	15	15	10
200	8"	120	130	175	200	209	253	21	25	15	15	10
250	10"	130	250	100	253	262	310	23	30	15	15	5
300	12"	210	130	100	301	325	370	24	30	17	18	5
350	14"	210	230	160	355	380	435	26	30	17	18	4
400	16"	220	235	-	400	417	477	28	35	19	19	3,5
450	18"	220	250	-	450	474	533	28	35	20	19	3,2
500	20"	270	200	100	495	515	585	30	40	25	20	2,8
600	24"	300	-	-	595	615	685	30	48	27	20	2,5
700	28"	300	-	-	700	716	786	30	48	27	20	2,5

Please consult with our technical department for different working conditions and design parameters.

# DESIGN VALUES

Body Material	EPDM, NBR, CR, SBR
Flange Material	Carbon Steel, Ductile Iron, Stainless Steel
Flange Norms	EN 1092, ANSI B16.5
Design Pressure	16 barg
Design Temperature	110°C

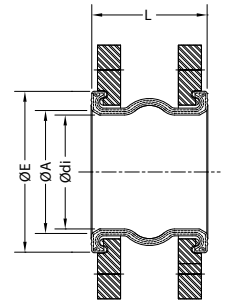

Effective Area	Max. Vacuum	Weight			Spring Rates			
	Without support Ring	wiht Flange S235JR Approx	with Flange GGG40 Approx.	as only Body Approx.	Axial Compression	Axial Extension	Lateral	Angular
cm <sup>2</sup>	bar abs.	kg	kg	kg	N/mm	N/mm	N/mm	Nm/deg.
15	0,7	2,6	-	0,15	20	26	69	0,06
20	0,7	3	2,2	0,185	50	65	85	0,15
20	0,7	3,5	3	0,185	50	65	85	0,15
32	0,7	4	3,5	0,215	50	65	138	0,45
44	0,7	5	4,5	0,305	52	70	150	0,75
65	0,7	7	5	0,365	60	80	165	1,2
101	0,7	8	5,5	0,44	60	80	185	2,8
149	0,6	11	7,5	0,705	65	85	185	5
210	0,6	13,5	10	0,92	110	145	190	9
358	0,6	18,5	12,5	1,49	129	170	245	16
558	0,5	25,5	19,5	2,275	175	230	325	36
777	0,4	38	23,5	5,45	255	330	240	45
1109	0,4	52	-	6,4	280	360	290	60
1457	0,4	65	-	7,5	310	400	335	80
1815	0,4	74	-	8	340	450	380	118
2171	0,3	90	-	9	390	510	310	115
3155	0,2	140	-	15	470	600	370	230
4240	0,2	153	-	18	520	690	427	325

# CENTRAL HEATING SYSTEM

## Expansion Joints

Significant displacements due to thermal movements on central heating pipes create thermal stresses result in bending of pipes and irritating noise. To prevent these problems, Central Heating System Type Expansion Joints may be preferred to absorb these movements.

This type of expansion joints are self-guided axial expansion joints. They can have threaded or weld ends specially constructed for heating pipelines.

These expansion joints are equipped with stainless steel bellows and balance of material is carbon steel unless otherwise asked for. They are protected with a cover against outer damages, and they can be mounted easily.

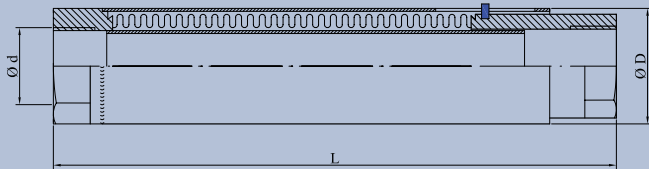

### Advantages

- » Deformations in pipes and noise resulting from thermal stresses are prevented
- » Minimum/maximum limits and pretension are observed easily with the help of limiting pin
- » Internal sleeve prevents pressure losses and misalignments while external cover prevents external damages. Internal sleeve (liner) also prevents "whistling" noise due to flow
- » Installation is easy and quick
- » Supplied ready to use
- » Low pressure loss

### Applications

- » Heating and ventilation systems, water pipes etc. in large buildings, hospitals and similar constructions
- » Domestic water pipe systems
- » At 70/90°C heating, one expansion joints per pipe length is sufficient to absorb movement of 30 metres of pipe in carbon steel
- » One unit is enough on average 10 floor building which is 30 metres tall in one direction

### DESIGN VALUES

Bellows Material	304, 316, 321
Balance of Material	Carbon Steel, Stainless Steel
Design Pressure	16 barg
Design Temperature	400°C
Design Movement	Axial ±25 mm

Nominal Diameter (DN)	DN15 (½")	DN20 (¾")	DN25 (1")	DN32 (1 ¼")	DN40 (1 ½")	DN50 (2")	DN65 (2 ½")	DN80 (3")	DN100 (4")
Outside Diameter D (mm)	35	42	51	60	63	70	99	114	139
Length L (mm)	260	260	260	260	260	260	260	260	260

Above DN65, comes with "socket weld" connection.

Please consult with our technical department for different working conditions and design parameters.

# VIBRATION ABSORBER

## Expansion Joints

Metal bellows can be used in applications where the vibration is high frequency and low amplitude.

Vibration absorbing expansion joints are manufactured from multi-ply bellows to absorb and dampen vibrations.

These expansion joint are equipped with tie rods for limiting the movements and absorbing the pressure of the pump raise, to prevent thrust forces from being transmitted into the pipe.

Available in various types of stainless steel materials, vibration expansion joint is adapted for all purposes and medium where temperatures are higher than rubber expansion joints limits.

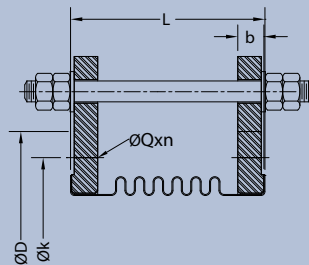

### Advantages

- » They are designed for versatile usage in systems where pump vibrations occur
- » Standard range is made from multi-ply bellows with several thin layers of stainless steel
- » Pressure and temperature bearing capacity, noise and vibration absorption and overall cyclic service life
- » Range of vibration absorbers can resolve many problems related to mechanical vibration and have a higher pressure and temperature rating than rubber bellows
- » Rubber bushes can be added on the tie rods to help reduce the noise

### Applications

- » Power stations
- » Pulp and paper plants
- » Heating and ventilating systems
- » Shipbuilding
- » Off-shore installations
- » Chemical/petrochemical plants

### DESIGN VALUES

Bellows Material	304, 316, 321
Balance of Material	Carbon Steel, Stainless Steel
Design Pressure	16 barg
Design Temperature	300°C

Nominal Diameter	Length (L) (mm)	Effective Area (cm <sup>2</sup> )	Spring Rates		EN 1092				
			Axial (N/mm)	Lateral (N/mm)	ØD (mm)	Øk (mm)	b (mm)	n	ØQ (mm)
50	130	37	88	102	165	125	16	4	18
65	130	57	94	149	185	145	16	4	18
80	130	79	85	234	200	160	18	8	18
100	130	131	105	292	220	180	18	8	18
125	130	186	148	745	250	210	20	8	18
150	130	269	217	1.544	285	240	20	8	22
200	130	443	260	2.909	340	295	22	12	22
250	160	664	282	3.130	405	355	24	12	26
300	210	942	313	2.498	460	410	26	12	26
350	210	1143	529	5.138	520	470	28	16	26
400	220	1484	371	2.878	580	525	30	16	30
450	220	1845	530	7.196	640	585	32	20	30
500	270	2262	450	5.331	715	650	34	20	33

Please consult with our technical department for different working conditions and design parameters.

# EXTERNALLY PRESSURIZED

## Expansion Joints

Externally pressurised expansion joints are the perfect solution when axial movements and pressure is high.

Bellows elements of externally pressurised expansion joints are arranged so that the media flow is on the external side of the bellows, while the inside part of the bellows is only subjected to atmospheric pressure with this side being in direct connection with the atmosphere.

External pressurising of the bellows eliminates column instability as a design limitation while permitting the absorption of large axial movement. While an internally pressurised bellows will become unstable and buckle due to internal pressure, pressure around an externally pressurised bellows will have a stabilising effect on the bellows. This makes it possible to achieve a construction of externally pressurised expansion joints with great flexibility for large axial compensation. With only the outside of the bellows subjected to pressure and the convolutions packed under a cover, the perfect conditions for external insulation or underground installation can be achieved.

As the convolutions of externally pressurised expansion joints are well protected under a cover, damage during transportation and installation is unlikely to occur but most importantly, the cover offers maximum protection against leaking bellows or bellows failure.

### Advantages

- » Externally pressurized expansion joints are used if there will be large axial movements
- » This type of expansion joint pressurizes the bellows externally, eliminating column instability concerns for the bellows
- » This configuration provides an outside cover protecting bellows from external elements and inside pipe acts as a liner protecting bellows from flow medium and streamlines the flow
- » Minimizing pressure losses

### Applications

- » Hot & Cold water pipelines
- » Superheated water
- » Steam and condensate pipelines
- » Industrial applications
- » HVAC lines
- » In large plants with thermal equilibrium and mechanical expansion
- » Geothermal plants
- » Integrated city district heating
- » The widest application area is underground pipe lines



# DESIGN VALUES

DN	25-1000
Bellows Material	304, 316, 321
Balance of Material	Carbon Steel, Stainless Steel
Design Pressure	up to 40 barg
Design Temperature	up to 400°C

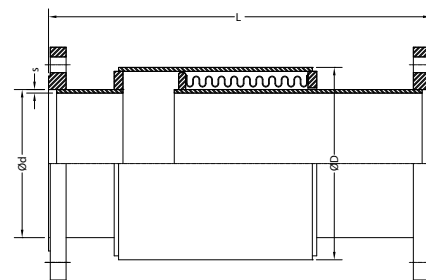

## Flanged End

Nominal Diameter (DN)	Design Pressure (barg)	Axial (-) (mm) Length (L) (mm)				Ød (mm)	s (mm)	ØD (mm)	Effective Area (cm <sup>2</sup> )
		30	60	90	120				
25 1"	40	275	395	520	-	33,7	2,6	88,9	54
32 1 1/4"	40	285	405	530	-	42,4	3,2	88,9	54
40 1 1/2"	40	295	415	535	-	48,3	3,2	88,9	54
50 2"	40	300	420	555	710	60,3	3,6	114,3	89
65 2 1/2"	40	315	430	560	715	76,1	3,6	114,3	91
80 3"	25	315	435	585	725	88,9	4,0	139,7	141
100 4"	25	320	450	585	750	114,3	4,5	165,0	196
125 5"	25	335	465	595	765	139,7	5,0	193,7	272
150 6"	25	345	475	615	790	165,0	5,0	219,1	346
200 8"	25	395	520	685	860	219,1	4,5	323,9	572
250 10"	25	420	585	760	950	273,0	5,6	355,6	829

## Weld End

Nominal Diameter (DN)	Design Pressure (barg)	Axial (-) (mm) Length (L) (mm)				Ød (mm)	s (mm)	ØD (mm)	Effective Area (cm <sup>2</sup> )
		30	60	90	120				
25 1"	40	275	395	520	-	33,7	2,6	88,9	54
32 1 1/4"	40	285	405	530	-	42,4	3,2	88,9	54
40 1 1/2"	40	295	415	535	-	48,3	3,2	88,9	54
50 2"	40	300	420	555	710	60,3	3,6	114,3	89
65 2 1/2"	40	315	430	560	715	76,1	3,6	114,3	91
80 3"	25	315	435	585	725	88,9	4,0	139,7	141
100 4"	25	320	450	585	750	114,3	4,5	165,0	196
125 5"	25	335	465	595	765	139,7	5,0	193,7	272
150 6"	25	345	475	615	790	165,0	5,0	219,1	346
200 8"	25	395	520	685	860	219,1	4,5	323,9	572
250 10"	25	420	585	760	950	273,0	5,6	355,6	829

Please consult with our technical department for different working conditions and design parameters.

# SEISMIC LIMIT ROD

## Expansion Joints

In addition to thermal movements in pipelines, there are mechanical movements due to earthquakes, ground settlements and landslides. These type of movements can cause significant damage to the piping systems in dilatation points of buildings, pipe junctions between vessels and boilers.

These mechanical movements can be absorbed by using seismic expansion joints.

### Advantages

- » Seismic expansion joints with rods is to absorb lateral and axial movements of both thermal and seismic origin.
- » With its limit rods, the expansion range can be set in adjusted range
- » High movement capacity and resistance to high temperatures and chemicals
- » Rotating flange, fixed flange or welding neck connection type are available

### Applications

- » Hot & Cold water pipelines
- » Fire fighting systems
- » Superheated water
- » Steam and condensate pipelines
- » Industrial Applications
- » Marine & Exhaust systems
- » HVAC lines





# DESIGN VALUES

DN	32 – 250
Bellows Material	304, 316, 321
Balance of Material	Carbon Steel, Stainless Steel
Design Pressure	16 barg
Design Temperature	400°C

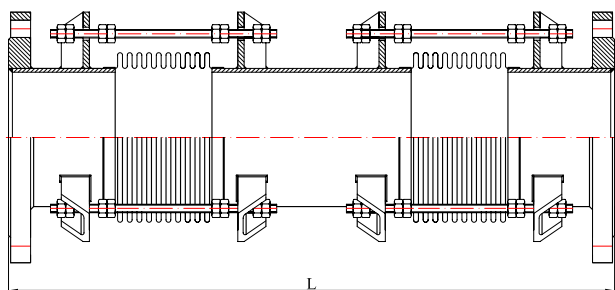

Nominal Diameter		Type 1			Type 2			Type 3		
		Movements (mm)		Length (L)	Movements (mm)		Length (L)	Movements (mm)		Length (L)
(DN)		Axial (+/-) (mm)	Lateral (+/-) (mm)	(mm)	Axial (+/-) (mm)	Lateral (+/-) (mm)	(mm)	Axial (+/-) (mm)	Lateral (+/-) (mm)	(mm)
32	1 1/4"	15	25	595	15	50	620	15	75	690
40	1 1/2"	15	25	620	15	50	650	15	75	720
50	2"	15	25	580	15	50	615	15	75	690
65	2 1/2"	15	25	620	15	50	660	15	75	735
		23	25	665	23	50	705	23	75	780
		30	25	710	30	50	750	30	75	825
80	3"	15	25	700	15	50	730	15	75	790
		23	25	750	23	50	780	23	75	835
		30	25	795	30	50	830	30	75	885
100	4"	15	25	750	15	50	790	15	75	825
		23	25	805	23	50	840	23	75	860
		30	25	860	30	50	895	30	75	915
125	5"	15	25	765	15	50	810	15	75	865
		23	25	810	23	50	875	23	75	910
		30	25	875	30	50	920	30	75	950
150	6"	15	25	840	15	50	890	15	75	945
		23	25	890	23	50	940	23	75	995
		30	25	940	30	50	985	30	75	1040
200	8"	15	25	885	15	50	960	15	75	1050
		23	25	935	23	50	1015	23	75	1100
		30	25	990	30	50	1065	30	75	1150
250	10"	15	25	885	15	50	930	15	75	1040
		23	25	930	23	50	985	23	75	1095
		30	25	985	30	50	1040	30	75	1150

Please consult with our technical department for different working conditions and design parameters.

Movements are non-concurrent

# SEISMIC GIMBALS

## Expansion Joints

The seismic gimbals expansion joints are designed to handle movements in all directions.

This type of expansion joints have a pair of gimbal joints on each end to absorb the movements which are occur because of earthquake and ground settlements.

### Advantages

- » Seismic expansion joints with gimbals are to absorb lateral and axial movements of both thermal and seismic origin
- » Lateral expansion level is directly related to bellow size and the length of the middle pipe
- » Designed for pressure thrust acting as a safety device
- » High movement capacity and resistance to high temperatures and chemicals
- » Rotating flange, fixed flange or welding neck connection types are available

### Applications

- » Hot & Cold water pipelines
- » Fire fighting systems
- » Superheated water
- » Steam and condensate pipelines
- » Industrial applications
- » Marine & Exhaust systems
- » HVAC lines

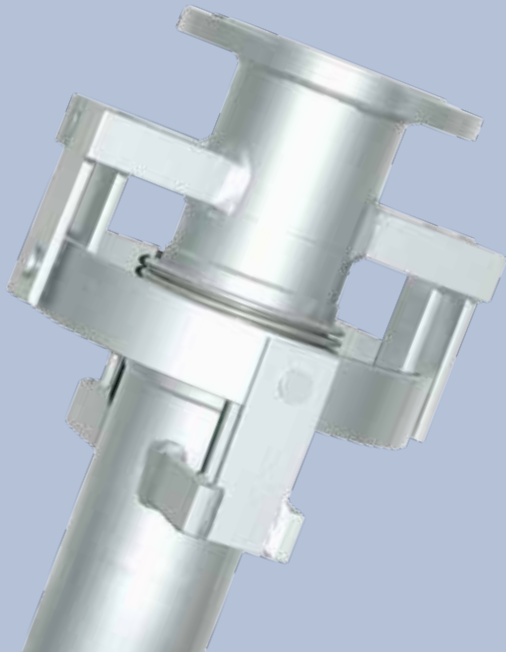

# DESIGN VALUES

DN	32 – 250
Bellows Material	304, 316, 321
Balance of Material	Carbon Steel, Stainless Steel
Design Pressure	16 barg
Design Temperature	400°C

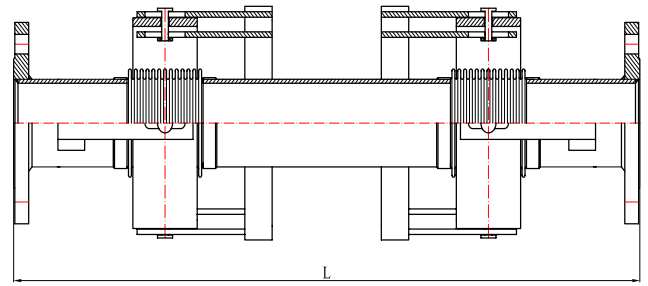

Nominal Diameter (DN)	Type 1					Type 2			
	Movements (mm)			Length (L)	Movements (mm)			Length (L)	
	Axial x (+/-)	Lateral y (+/-)	Lateral z (+/-)	(mm)	Axial x (+/-)	Lateral y (+/-)	Lateral z (+/-)	(mm)	
32 1 1/4"	50	100	100	750	50	200	200	750	
40 1 1/2"	50	100	100	790	50	200	200	790	
50 2"	50	100	100	790	50	200	200	790	
65 2 1/2"	50	100	100	940	50	200	200	940	
80 3"	50	100	100	940	50	200	200	940	
100 4"	50	100	100	940	50	200	200	990	
125 5"	50	100	100	940	50	200	200	1090	
150 6"	50	100	100	1100	50	200	200	1200	
200 8"	50	100	100	1130	50	200	200	1330	
250 10"	50	100	100	1130	50	200	200	1430	

Please consult with our technical department for different working conditions and design parameters.

Movements are non-concurrent

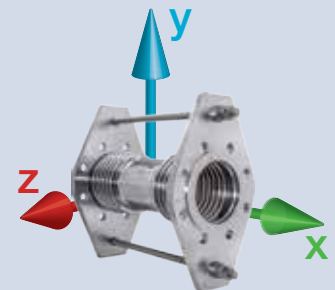

In addition to thermal movements in pipe lines, there are mechanical movements due to earthquakes, ground settlements and landslides. These type of movements can cause significant damage to the piping systems in dilatation points of buildings, pipe junctions between vessels and boilers.

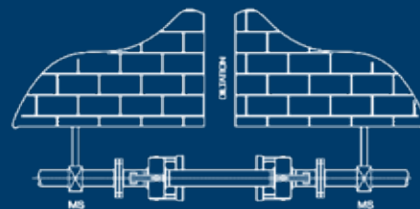

These mechanical movements can be absorbed by using seismic expansion joints.

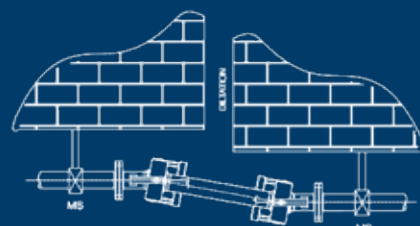

# LENS

## Expansion Joints

Lens bellows can be the right solution to piping, ducting and vessel thermal growth problems compared to conventional thin walled metal bellows.

Thick-wall expansion joints are used primarily in heat exchangers and large diameter piping systems where thin-wall expansion joints would not be sufficient.

### Advantages

- » Dents and gouges create stress risers in thin ply bellows which result in fatigue cracks over time
- » Lens bellows have the advantage of holding up to mechanical damage better than thin wall bellows
- » Sizes from DN200-DN8000
- » Thicker wall of lens bellows holds up better to corrosion attacks
- » Weld repair can be performed by plant maintenance staff on thick walled bellows
- » Drain couplings can be added to the bottom of the convolution to prevent condensate build up
- » Common use of carbon steel material
- » Limitless convolution height
- » Thick walled, high convolution is durable and lasts for a long time

### Applications

- » Iron and Steel Industry
- » Mining Industry
- » Chemical Industry
- » Power Stations
- » Cement Industry

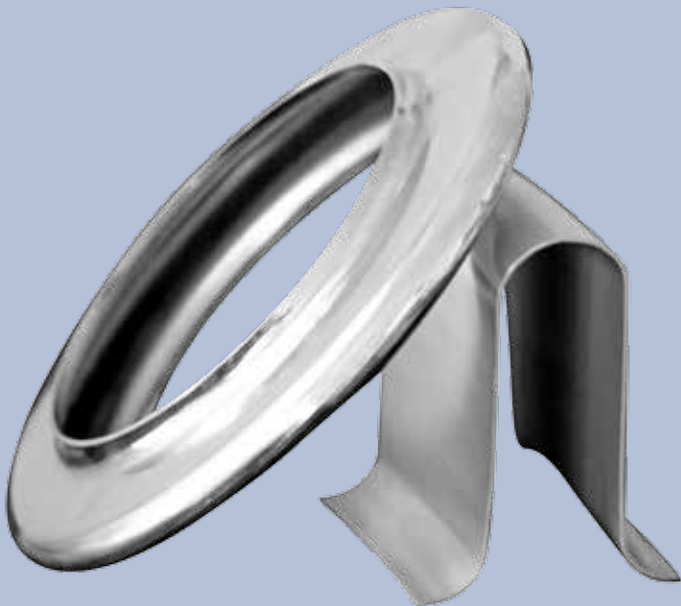

# DESIGN VALUES

DN	300-8000
Bellows Material	304, 316, 321, P265GH, 16Mo3, etc
Connection Material	Carbon Steel, Stainless Steel

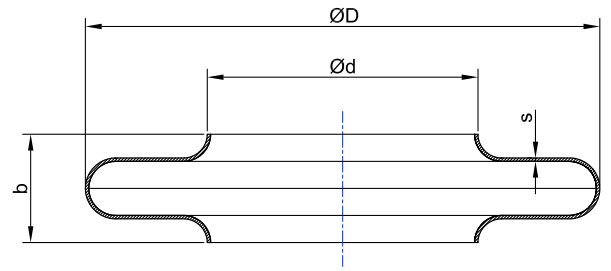

Nominal Diameter (DN)		Ød (mm)	ØD (mm)	b (mm)	Thickness (s) (mm)
300	12"	306	550	120-160	2-4
400	16"	408	700	120-160	2-4
500	20"	508	800	120-160	2-4
600	24"	610	900	120-160	2-4
700	28"	711	1000	120-160	2-4
800	32"	813	1100	120-160	2-4
900	36"	914	1200	120-160	2-4
1000	40"	1016	1300	120-160	2-4
1100	44"	1120	1480	160	2-4
1200	48"	1220	1580	160	2-4
1300	52"	1320	1680	160	2-4
1400	56"	1420	1780	160	2-4
1500	60"	1520	1880	160	2-4
1600	64"	1620	2020	160	2-4
1700	68"	1720	2120	160	2-4
1800	72"	1820	2220	160	2-4
1900	76"	1920	2320	160	2-4
2000	80"	2020	2500	160	2-6
2100	84"	2120	2600	160	2-6
2200	88"	2220	2700	160	2-6
2300	92"	2320	2800	160	2-6
2400	96"	2420	2900	160	2-6
2500	100"	2520	3000	160	2-6
2600	104"	2620	3100	160	2-6
2700	108"	2720	3200	160	2-6
2800	112"	2820	3300	160	2-6
2900	116"	2920	3400	160	2-6
3000	120"	3020	3500	160	2-6

Please consult with our technical department for different working conditions and design parameters.

# RECTANGULAR

## Expansion Joints

Rectangular metal expansion joints are designed to absorb movements in all three directions i.e. axial, lateral and angular. Rectangular bellows are mostly used for very low pressure applications such as ducts, exhaust systems, ventilation systems etc.

### Advantages

- » They can be designed and manufactured in various corner types in accordance with required operating conditions
- » Compensation on thermal expansion

### Applications

- » Chemical process plants
- » Cement manufacturing
- » Pulp and paper industry
- » Power stations
- » Refineries
- » Shipbuilding
- » Steel plants
- » Sugar plants
- » Gas turbine installation

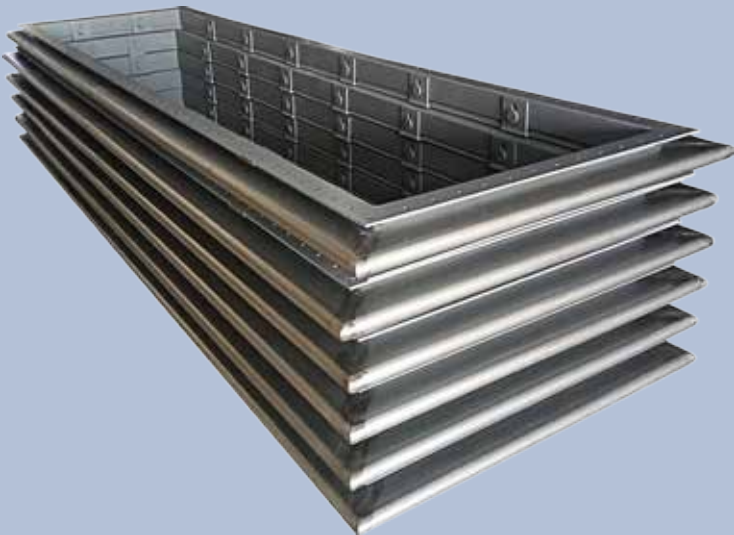

# FABRIC

## Expansion Joints

Fabric expansion joints are extremely flexible and can be made from a variety of special woven fabrics coated or laminated with selected elastomers or fluoropolymers. Fabric expansion joints are used to insulate, to avoid mechanical loads and to protect against abrasion. They offer advantages for the pipe work designer as they can absorb movements simultaneously in several directions. Further, they have almost no reactive forces and require little space. Fabric expansion joints are easy to customise to suit existing operating conditions and are easy to transport and install. In comparison to metallic expansion joints fabric offers almost unlimited flexibility, giving the piping designer more options.

### Advantages

- » They can be designed and manufactured in various types in accordance with required operating conditions
- » High vibration and noise elimination
- » Compensation on thermal expansion
- » High flexibility
- » Working temperature up to 850°C
- » Minimum reaction force

### Applications

- » Chemical process plants
- » Cement manufacturing
- » Pulp and paper industry
- » Power stations
- » Refineries
- » Shipbuilding
- » Steel plants
- » Sugar plants
- » Gas turbine installations

### DESIGN VALUES

Design Pressure	up to 1 barg
Design Temperature	850°C



# BLNC I

## Type Approved Expansion Joints

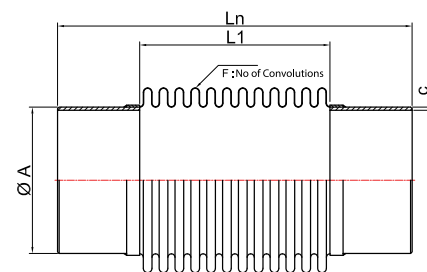

### DESIGN VALUES

Bellows Material	321, 316, 316L
Weld-End Material	Carbon Steel, Stainless Steel
Design Pressure	2,5 barg
Design Temperature	550°C
Design No	PT-001-BAL.0

Expansion joints DN450 through DN1000 have 1mm thick liners



Nominal Diameter	Length (Ln) (mm)	Bellows					Pipe		
		Number of Convolutions	Number of Plies	Ply Thickness (mm)	L1 (mm)	ØD (mm)	ØA (mm)	c (mm)	
32	1 1/4"	205	26	1	0,3	105	52	42,4	2,6
40	1 1/2"	205	22	1	0,3	105	60	48,3	2,6
50	2"	245	13	2	0,3	120	78	60,3	2,9
65	2 1/2"	245	13	2	0,3	120	96	76,1	2,9
80	3"	245	13	2	0,3	120	110	88,9	3,2
90	3.5"	245	13	2	0,3	120	122	101,6	3,2
100	4"	245	11	2	0,3	120	140	114,3	3,6
125	5"	245	11	2	0,3	120	166	139,7	3,6
150	6"	245	9	2	0,3	120	200	168,3	4,0
175	7"	245	9	2	0,3	120	226	193,7	4,5
200	8"	245	9	2	0,3	120	251	219,1	4,5
250	10"	245	9	2	0,3	120	305	273	5,0
300	12"	295	9	2	0,3	145	361	323,9	5,6
350	14"	295	9	2	0,3	145	393	355,6	5,6
400	16"	295	9	2	0,3	145	443	406,4	5,6
450	18"	300	8	2	0,4	176	509	457	8,0
500	20"	340	9	2	0,4	216	564	508	8,0
600	24"	340	9	2	0,4	216	669	609	10,0
700	28"	380	6	2	0,4	168	779	711	10,0
800	32"	380	6	2	0,4	180	888	812	10,0
900	36"	380	5	2	0,5	170	998	914	10,0
1000	40"	380	5	2	0,5	190	1108	1016	10,0



# BLNC IF

## Type Approved Expansion Joints

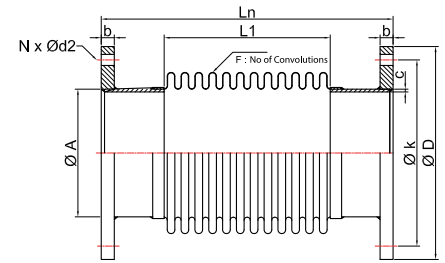

### DESIGN VALUES

Bellows Material	321, 316, 316L
Flange&Weld-End Material	Carbon Steel, Stainless Steel
Design Pressure	2,5 barg
Design Temperature	550°C
Design No	PT-007-BALF.0

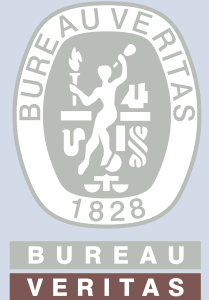

Expansion joints DN450 through DN1000 have 1mm thick liners

Nominal Diameter	Length (Ln) (mm)	Bellows					Pipe			Flange			
		Number of Convolutions	Number of Plies	Ply Thickness (mm)	L1 (mm)	ØD (mm)	ØA (mm)	c (mm)	ØD (mm)	b (mm)	Øk (mm)	N x Ød2	
32	1 1/4"	205	26	1	0,3	105	52	42,4	2,6	140	16	100	4 x 18
40	1 1/2"	205	22	1	0,3	105	60	48,3	2,6	150	16	110	4 x 18
50	2"	245	13	2	0,3	120	78	60,3	2,9	165	16	125	4 x 18
65	2 1/2"	245	13	2	0,3	120	96	76,1	2,9	185	16	145	4 x 18
80	3"	245	13	2	0,3	120	110	88,9	3,2	200	16	160	8 x 18
90	3.5"	245	13	2	0,3	120	122	101,6	3,2	220	16	180	8 x 18
100	4"	245	11	2	0,3	120	140	114,3	3,6	220	16	180	8 x 18
125	5"	245	11	2	0,3	120	166	139,7	3,6	250	16	210	8 x 18
150	6"	245	9	2	0,3	120	200	168,3	4,0	285	16	240	8 x 22
175	7"	245	9	2	0,3	120	226	193,7	4,5	315	16	270	8 x 22
200	8"	245	9	2	0,3	120	251	219,1	4,5	320	16	280	8 x 18
250	10"	245	9	2	0,3	120	305	273	5,0	375	16	335	12 x 18
300	12"	295	9	2	0,3	145	361	323,9	5,6	440	16	395	12 x 22
350	14"	295	9	2	0,3	145	393	355,6	5,6	490	16	445	12 x 22
400	16"	295	9	2	0,3	145	443	406,4	5,6	540	16	495	16 x 22
450	18"	300	8	2	0,4	176	509	457	8,0	595	16	550	16 x 22
500	20"	340	9	2	0,4	216	564	508	8,0	645	16	600	20 x 22
600	24"	340	9	2	0,4	216	669	609	10,0	754	20	700	20 x 22
700	28"	380	6	2	0,4	168	779	711	10,0	856	20	800	24 x 22
800	32"	380	6	2	0,4	180	888	812	10,0	958	20	900	24 x 22
900	36"	380	5	2	0,5	170	998	914	10,0	1060	20	1010	28 x 22
1000	40"	380	5	2	0,5	190	1108	1016	10,0	1162	20	1110	32 x 22

# BLNC II

## Type Approved Expansion Joints

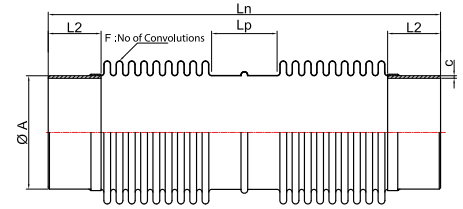

### DESIGN VALUES

Bellows Material	321, 316, 316L
Weld-End Material	Carbon Steel, Stainless Steel
Design Pressure	2,5 barg
Design Temperature	550°C
Design No	PT-002-BAL2.0



**BUREAU  
VERITAS**

Nominal Diameter		Length (Ln) (mm)	Bellows				Pipe			
			Number of Convolutions	Number of Plies	Ply Thickness (mm)	ØD (mm)	ØA (mm)	c (mm)	L2 (mm)	LP (mm)
40	1 1/2"	375	20 x 2	1	0,3	61	48,3	2,6	40	101
50	2"	375	17 x 2	2	0,3	77	60,3	2,9	40	100
65	2 1/2"	345	11 x 2	2	0,3	95	76,1	3,2	40	111
80	3"	380	13 x 2	2	0,3	111	88,9	3,2	40	115
100	4"	330	9 x 2	2	0,3	140	114,3	3,6	40	113
125	5"	320	9 x 2	2	0,3	168	139,7	3,6	40	100
150	6"	395	10 x 2	2	0,3	200	168,3	4,0	50	107
175	7"	395	10 x 2	2	0,3	228	193,7	4,5	50	107
200	8"	405	8 x 2	2	0,3	255	219,1	4,5	50	116
250	10"	405	7 x 2	2	0,3	315	273	5,0	50	116
300	12"	415	6 x 2	2	0,3	372	323,9	6,0	70	88
350	14"	415	6 x 2	2	0,3	406	355,6	6,0	70	88
400	16"	485	6 x 2	2	0,3	459	406,4	6,0	70	115
450	18"	490	5 x 2	2	0,4	511	457	6,0	70	120
500	20"	460	5 x 2	2	0,4	564	508	6,0	70	115

# BLNC IIF

## Type Approved Expansion Joints

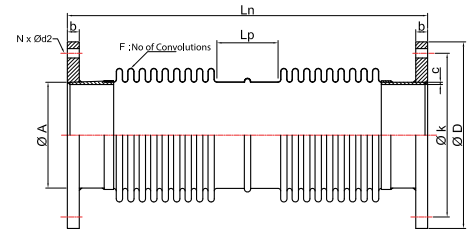

### DESIGN VALUES

Bellows Material	321, 316, 316L
Flange&Weld-End Material	Carbon Steel, Stainless Steel
Design Pressure	2,5 barg
Design Temperature	550°C
Design No	PT-008-BAL2F.0

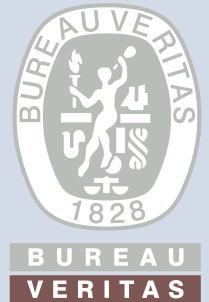

Nominal Diameter	Length (Ln) (mm)	Bellows				Pipe				Flange			
		Number of Convolutions	Number of Plies	Ply Thickness (mm)	ØD (mm)	ØA (mm)	c (mm)	Lp (mm)	ØD (mm)	b (mm)	Øk (mm)	N x Ød2	
40	1 1/2"	375	20 x 2	1	0,3	60,5	48,3	2,6	101	150	16	110	4 x 18
50	2"	375	17 x 2	2	0,3	77	60,3	2,9	100	165	16	125	4 x 18
65	2 1/2"	345	11 x 2	2	0,3	95	76,1	3,2	111	185	16	145	4 x 18
80	3"	380	13 x 2	2	0,3	111	88,9	3,2	115	200	16	160	8 x 18
100	4"	330	9 x 2	2	0,3	140	114,3	3,6	113	220	16	180	8 x 18
125	5"	320	9 x 2	2	0,3	168	139,7	3,6	100	250	16	210	8 x 18
150	6"	395	10 x 2	2	0,3	200	168,3	4,0	107	285	16	240	8 x 22
175	7"	395	10 x 2	2	0,3	228	193,7	4,5	107	315	16	270	8 x 22
200	8"	405	8 x 2	2	0,3	255	219,1	4,5	116	320	16	280	8 x 18
250	10"	405	7 x 2	2	0,3	315	273	5,0	116	375	16	335	12 x 18
300	12"	415	6 x 2	2	0,3	372	323,9	6,0	88	440	16	395	12 x 22
350	14"	415	6 x 2	2	0,3	406	355,6	6,0	88	490	16	445	12 x 22
400	16"	485	6 x 2	2	0,3	458,5	406,4	6,0	115	540	16	495	16 x 22
450	18"	490	5 x 2	2	0,4	511	457	6,0	120	595	16	550	16 x 22
500	20"	460	5 x 2	2	0,4	564	508	6,0	115	645	16	600	20 x 22

# BLNC III - IIIF

## Type Approved Expansion Joints

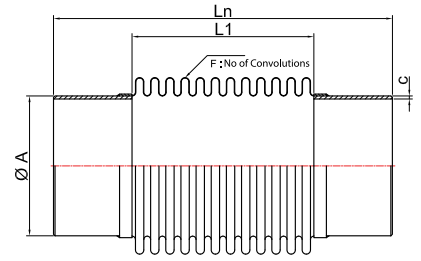

### DESIGN VALUES

Bellows Material	321, 316, 316L
Flange&Weld-End Material	Carbon Steel, Stainless Steel
Design Pressure	2,5 barg
Design Temperature	550°C
Design No	PT-003-BAL3.0 PT-009-BAL3F.0

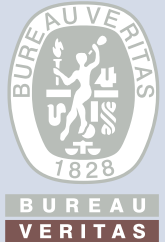

#### PT-003-BAL3.0

Nominal Diameter		Length (Ln) (mm)	Bellows				Pipe		
			Number of Convolutions	Number of Plies	Ply Thickness (mm)	L1 (mm)	ØD (mm)	ØA (mm)	c (mm)
100	4"	285	15	2	0,3	165	140	114,3	3,6
125	5"	295	15	2	0,3	165	166	139,7	3,6
150	6"	295	13	2	0,3	175	200	168,3	4,0
200	8"	315	13	2	0,3	175	251	219,1	4,5
250	10"	315	13	2	0,3	175	305	273	5,0
300	12"	345	13	2	0,3	210	361	323,9	5,6
350	14"	345	13	2	0,3	210	393	355,6	5,6

#### PT-009-BAL3F.0

Nominal Diameter		Length (Ln) (mm)	Bellows				Pipe		Flange				
			Number of Convolutions	Number of Plies	Ply Thickness (mm)	L1 (mm)	ØD (mm)	ØA (mm)	c (mm)	ØD (mm)	b (mm)	Øk (mm)	N x Ød2
100	4"	285	15	2	0,3	165	140	114,3	3,6	220	16	180	8 x 18
125	5"	295	15	2	0,3	165	166	139,7	3,6	250	16	210	8 x 18
150	6"	295	13	2	0,3	175	200	168,3	4,0	285	16	240	8 x 22
200	8"	315	13	2	0,3	175	251	219,1	4,5	320	16	280	8 x 18
250	10"	315	13	2	0,3	175	305	273	5,0	375	16	335	12 x 18
300	12"	345	13	2	0,3	210	361	323,9	5,6	440	16	395	12 x 22
350	14"	345	13	2	0,3	210	393	355,6	5,6	490	16	445	12 x 22

# BLNC IV - IVF

## Type Approved Expansion Joints

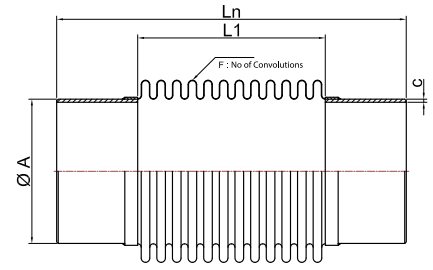

### DESIGN VALUES

Bellows Material	321, 316, 316L
Flange&Weld-End Material	Carbon Steel, Stainless Steel
Design Pressure	2,5 barg
Design Temperature	550°C
Design No	PT-004-BAL4.0 PT-010-BAL4F.0



#### PT-004-BAL4.0

Nominal Diameter		Length (Ln) (mm)	Bellows				Pipe		
			Number of Convolutions	Number of Plies	Ply Thickness (mm)	L1 (mm)	ØD (mm)	ØA (mm)	c (mm)
40	1 1/2"	150	18	1	0,3	90	60	48,3	2,6
50	2"	150	10	2	0,3	90	78	60,3	2,9
65	2 1/2"	150	10	2	0,3	90	96	76,1	2,9
80	3"	150	10	2	0,3	90	110	88,9	3,2
100	4"	150	7	2	0,3	77	140	114,3	3,6
125	5"	150	7	2	0,3	77	166	139,7	3,6
150	6"	150	6	2	0,3	80	200	168,3	4,0
200	8"	150	6	2	0,3	80	251	219,1	4,5
250	10"	150	6	2	0,3	80	305	273	5,0
300	12"	150	5	2	0,3	80	361	323,9	5,6

#### PT-010-BAL4F.0

Nominal Diameter		Length (Ln) (mm)	Bellows				Pipe		Flange				
			Number of Convolutions	Number of Plies	Ply Thickness (mm)	L1 (mm)	ØD (mm)	ØA (mm)	c (mm)	ØD (mm)	b (mm)	Øk (mm)	N x Ød2
40	1 1/2"	150	18	1	0,3	90	60	48,3	2,6	150	16	100	4 x 18
50	2"	150	10	2	0,3	90	78	60,3	2,9	165	16	125	4 x 18
65	2 1/2"	150	10	2	0,3	90	96	76,1	2,9	185	16	145	4 x 18
80	3"	150	10	2	0,3	90	110	88,9	3,2	200	16	160	8 x 18
100	4"	150	7	2	0,3	77	140	114,3	3,6	220	16	180	8 x 18
125	5"	150	7	2	0,3	77	166	139,7	3,6	250	16	210	8 x 18
150	6"	150	6	2	0,3	80	200	168,3	4,0	285	16	240	8 x 22
200	8"	150	6	2	0,3	80	251	219,1	4,5	320	16	280	8 x 18
250	10"	150	6	2	0,3	80	305	273	5,0	375	16	335	12 x 18
300	12"	150	5	2	0,3	80	361	323,9	5,6	440	16	395	12 x 22

# BLNC V

## Type Approved Expansion Joints

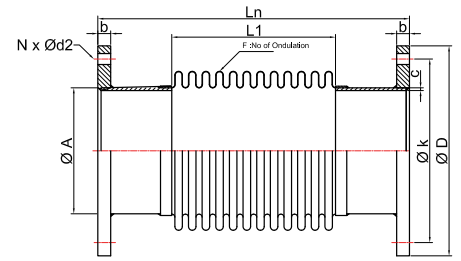

### DESIGN VALUES

Bellows Material	321, 316, 316L
Flange&Weld-End Material	Carbon Steel, Stainless Steel
Design Pressure	2,5 barg
Design Temperature	550°C
Design No	PT-005-BAL5.0



**BUREAU  
VERITAS**

Nominal Diameter	Length (L <sub>n</sub> ) (mm)	Bellows					Pipe			Flange			
		Number of Convolutions	Number of Plies	Ply Thickness (mm)	L <sub>1</sub> (mm)	ØD (mm)	ØA (mm)	c (mm)	ØD (mm)	b (mm)	Øk (mm)	N x Ød <sub>2</sub>	
40	1 1/2"	215	22	1	0,3	105	60	48,3	2,6	150	18	110	4 x 18
50	2"	255	13	2	0,3	120	78	60,3	2,9	165	18	125	4 x 18
65	2 1/2"	255	13	2	0,3	120	96	76,1	2,9	185	18	145	4 x 18
80	3"	255	13	2	0,3	120	110	88,9	3,2	200	20	160	8 x 18
90	3.5"	255	13	2	0,3	120	122	101,6	3,2	220	20	180	8 x 18
100	4"	255	11	2	0,3	120	140	114,3	3,6	220	20	180	8 x 18
125	5"	255	11	2	0,3	120	166	139,7	3,6	250	22	210	8 x 18
150	6"	255	9	2	0,3	120	200	168,3	4,0	285	22	240	8 x 22
175	7"	255	9	2	0,3	120	226	193,7	4,5	315	24	270	8 x 22
200	8"	255	9	2	0,3	120	251	219,1	4,5	340	24	295	8 x 22
250	10"	255	9	2	0,3	120	305	273	5	395	26	350	12 x 22
300	12"	305	9	2	0,3	145	361	323,9	5,6	445	26	400	12 x 22
350	14"	305	9	2	0,3	145	393	355,6	5,6	505	26	460	16 x 22
400	16"	305	9	2	0,3	145	443	406,4	5,6	565	26	515	16 x 26

# BLNC VI

## Type Approved Expansion Joints

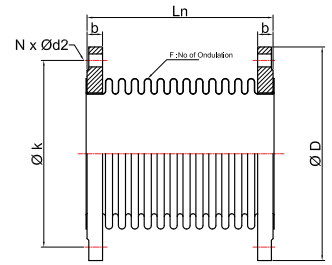

### DESIGN VALUES

Bellows Material	321, 316, 316L
Flange Material	Carbon Steel, Stainless Steel
Design Pressure	16 barg
Design Temperature	550°C
Design No	PT-006-BAL6.0

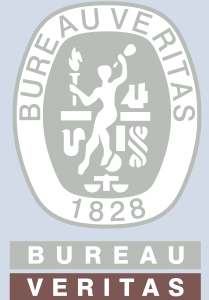

Nominal Diameter		Length (Ln) (mm)	Bellows				Flange			
			Number of Convolutions	Number of Plies	Ply Thickness (mm)	ØD (mm)	ØD (mm)	b (mm)	Øk (mm)	ØN x d2
40	1 1/2"	130	20	1	0,3	60,5	150	16	110	4 x 18
50	2"	130	16	2	0,3	77	165	18	125	4 x 18
65	2 1/2"	130	14	2	0,3	95	185	18	145	4 x 18
80	3"	130	13	2	0,3	111	200	20	160	8 x 18
100	4"	130	12	2	0,3	140	220	20	180	8 x 18
125	5"	130	12	2	0,3	168	250	22	210	8 x 18
150	6"	130	12	2	0,4	200	285	22	240	8 x 22
200	8"	130	8	2	0,4	255	340	24	295	12 x 22
250	10"	130	7	2	0,4	315	395	26	355	12 x 26
300	12"	130	6	2	0,4	372	460	28	410	12 x 26

# RF 30-60 AXIAL

## Type Approved Expansion Joints

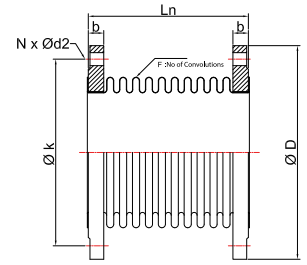

### DESIGN VALUES

Bellows Material	321, 316, 316L
Flange Material	Carbon Steel, Stainless Steel
Design Pressure	16 barg
Design Temperature	550°C
Connection Type	Rotating Flange
Design No	PT-011-RF30.0 PT-012-RF60.0

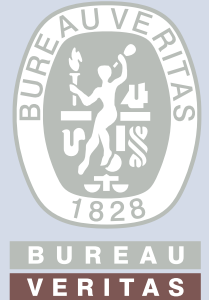

### DESIGN NO: PT-011-RF30.0

Nominal Diameter		Length (Ln) (mm)	Bellows				Flange			
			Number of Convolutions	Number of Plies	Ply Thickness (mm)	ØD (mm)	ØD (mm)	b (mm)	Øk (mm)	N x Ød2
40	1 1/2"	120	18	1	0,3	60,5	150	16	110	4 x 18
50	2"	120	14	1	0,4	77	165	18	125	4 x 18
65	2 1/2"	120	12	1	0,4	95	185	18	145	4 x 18
80	3"	120	11	1	0,5	111	200	20	160	8 x 18
100	4"	120	10	1	0,5	140	220	20	180	8 x 18
125	5"	125	10	1	0,6	168	250	22	210	8 x 18
150	6"	130	10	1	0,6	200	285	22	240	8 x 22
200	8"	150	8	1	0,8	255	340	24	295	12 x 22
250	10"	165	8	1	0,8	315	405	26	355	12 x 26
300	12"	170	7	1	0,8	372	460	28	410	12 x 26

### DESIGN NO: PT-012-RF60.0

Nominal Diameter		Length (Ln) (mm)	Bellows				Flange			
			Number of Convolutions	Number of Plies	Ply Thickness (mm)	ØD (mm)	ØD (mm)	b (mm)	Øk (mm)	N x Ød2
65	2 1/2"	180	20	1	0,4	95	185	18	145	4 x 18
80	3"	180	19	1	0,5	111	200	20	160	8 x 18
100	4"	185	18	1	0,5	140	220	20	180	8 x 18
125	5"	190	18	1	0,6	168	250	22	210	8 x 18
150	6"	200	18	1	0,6	200	285	22	240	8 x 22
200	8"	230	14	1	0,8	255	340	24	295	12 x 22
250	10"	245	14	1	0,8	315	405	26	355	12 x 26
300	12"	250	12	1	0,8	372	460	28	410	12 x 26



# FF 30-60 AXIAL

## Type Approved Expansion Joints

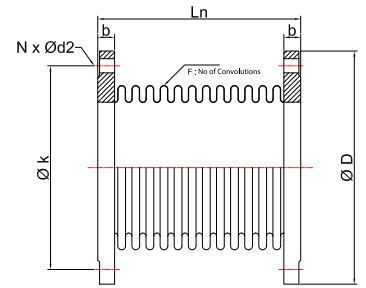

### DESIGN VALUES

Bellows Material	321, 316, 316L
Flange Material	Carbon Steel, Stainless Steel
Design Pressure	16 barg
Design Temperature	550°C
Connection Type	Fixed Flange
Design No	PT-013-FF30.0 PT-014-FF60.0

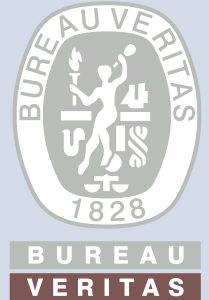

### DESIGN NO: PT-013-FF30.0

Nominal Diameter	Length (Ln) (mm)	Bellows				Flange				
		Number of Convolutions	Number of Plies	Ply Thickness (mm)	ØD (mm)	ØD (mm)	b (mm)	Øk (mm)	N x Ød2	
40	1 1/2"	120	18	1	0,3	60,5	150	16	110	4 x 18
50	2"	120	14	1	0,4	77	165	18	125	4 x 18
65	2 1/2"	120	12	1	0,4	95	185	18	145	4 x 18
80	3"	120	11	1	0,5	111	200	20	160	8 x 18
100	4"	120	10	1	0,5	140	220	20	180	8 x 18
125	5"	125	10	1	0,6	168	250	22	210	8 x 18
150	6"	130	10	1	0,6	200	285	22	240	8 x 22
200	8"	150	8	1	0,8	255	340	24	295	12 x 22
250	10"	165	8	1	0,8	315	405	26	355	12 x 26
300	12"	170	7	1	0,8	372	460	28	410	12 x 26

### DESIGN NO: PT-014-FF60.0

Nominal Diameter	Length (Ln) (mm)	Bellows				Flange				
		Number of Convolutions	Number of Plies	Ply Thickness (mm)	ØD (mm)	ØD (mm)	b (mm)	Øk (mm)	N x Ød2	
65	2 1/2"	180	20	1	0,4	95	185	18	145	4 x 18
80	3"	180	19	1	0,5	111	200	20	160	8 x 18
100	4"	185	18	1	0,5	140	220	20	180	8 x 18
125	5"	190	18	1	0,6	168	250	22	210	8 x 18
150	6"	200	18	1	0,6	200	285	22	240	8 x 22
200	8"	230	14	1	0,8	255	340	24	295	12 x 22
250	10"	245	14	1	0,8	315	405	26	355	12 x 26
300	12"	250	12	1	0,8	372	460	28	410	12 x 26

# BLNC VIII

## Type Approved Expansion Joints

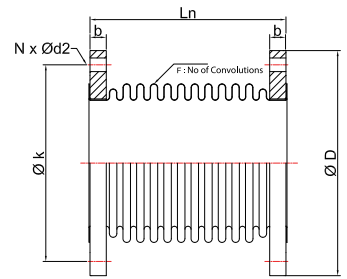

### DESIGN VALUES

Bellows Material	321, 316, 316L
Weld-End Material	Carbon Steel, Stainless Steel
Design Pressure	2,5 barg
Design Temperature	550°C
Design No	US1BU-03



**BUREAU  
VERITAS**

Nominal Diameter		Length (Ln) (mm)	Bellows			Flange			
			Number of Convolutions	Number of Plies	Ply Thickness (mm)	ØD (mm)	b (mm)	Øk (mm)	N x Ød2
80	3.5"	180	16	2	0,3	200	20	160	8 x 18
100	4"	150	14	2	0,3	220	20	180	8 x 18
125	5"	185	13	2	0,3	250	22	210	8 x 18
150	6"	200	13	2	0,3	285	22	240	8 x 22
175	7"	205	13	2	0,3	315	22	270	8 x 22
200	8"	185	12	2	0,3	320	16	280	8 x 18
250	10"	185	11	2	0,4	375	16	335	12 x 18
300	12"	180	9	2	0,4	440	16	395	12 x 22
350	14"	180	9	2	0,4	490	16	445	12 x 22
400	16"	220	11	2	0,4	540	16	495	16 x 22
450	18"	180	8	2	0,4	595	16	550	16 x 22
500	20"	230	9	2	0,4	645	16	600	20 x 22
550	22"	240	9	2	0,4	703	20	650	20 x 22
600	24"	230	8	2	0,4	754	20	700	20 x 22
700	28"	230	7	2	0,4	856	20	800	24 x 22
800	32"	230	7	2	0,5	958	20	900	24 x 22
900	36"	230	6	2	0,5	1060	20	1010	28 x 22
1000	40"	230	5	2	0,5	1162	20	1110	32 x 22
1100	44"	230	5	2	0,6	1266	20	1210	32 x 22
1200	48"	230	5	2	0,6	1366	20	1310	36 x 22

# BLNC IX

## Type Approved Expansion Joints

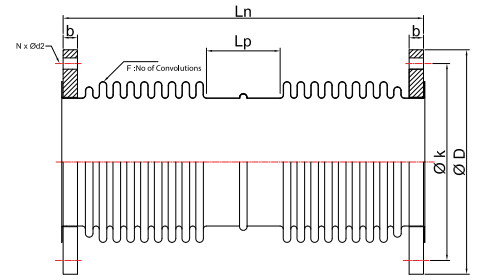

### DESIGN VALUES

Bellows Material	321, 316, 316L
Weld-End Material	Carbon Steel, Stainless Steel
Design Pressure	2,5 barg
Design Temperature	550°C
Design No	US3BU-03

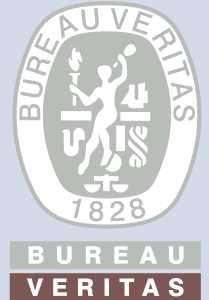

			Bellows				Flange			
Nominal Diameter		Length (Ln) (mm)	Lp (mm)	Number of Convolutions	Number of Plies	Ply Thickness (mm)	ØD (mm)	b (mm)	Øk (mm)	N x Ød2
80	3.5"	340	115	2 x 11	2	0,3	200	20	160	8 x 18
100	4"	290	115	2 x 7	2	0,3	220	20	180	8 x 18
125	5"	285	105	2 x 8	2	0,3	250	22	210	8 x 18
150	6"	340	105	2 x 8	2	0,3	285	22	240	8 x 22
175	7"	345	120	2 x 7	2	0,3	315	22	270	8 x 22
200	8"	335	120	2 x 7	2	0,4	320	16	280	8 x 18
250	10"	335	115	2 x 7	2	0,4	375	16	335	12 x 18
300	12"	310	85	2 x 6	2	0,4	440	16	395	12 x 22
350	14"	310	85	2 x 6	2	0,4	490	16	445	12 x 22
400	16"	375	110	2 x 7	2	0,5	540	16	495	16 x 22
450	18"	380	120	2 x 6	2	0,5	595	16	550	16 x 22
500	20"	350	120	2 x 5	2	0,5	645	16	600	20 x 22
550	22"	360	110	2 x 5	2	0,5	703	20	650	20 x 22
600	24"	440	135	2 x 6	2	0,5	754	20	700	20 x 22
700	28"	465	165	2 x 5	2	0,5	856	20	800	24 x 22
800	32"	465	165	2 x 5	2	0,5	958	20	900	24 x 22
900	36"	465	170	2 x 4	2	0,5	1060	20	1010	28 x 22
1000	40"	465	175	2 x 3	2	0,5	1162	20	1110	32 x 22
1100	44"	465	175	2 x 3	2	0,6	1266	20	1210	32 x 22
1200	48"	465	175	2 x 3	2	0,6	1366	20	1310	36 x 22

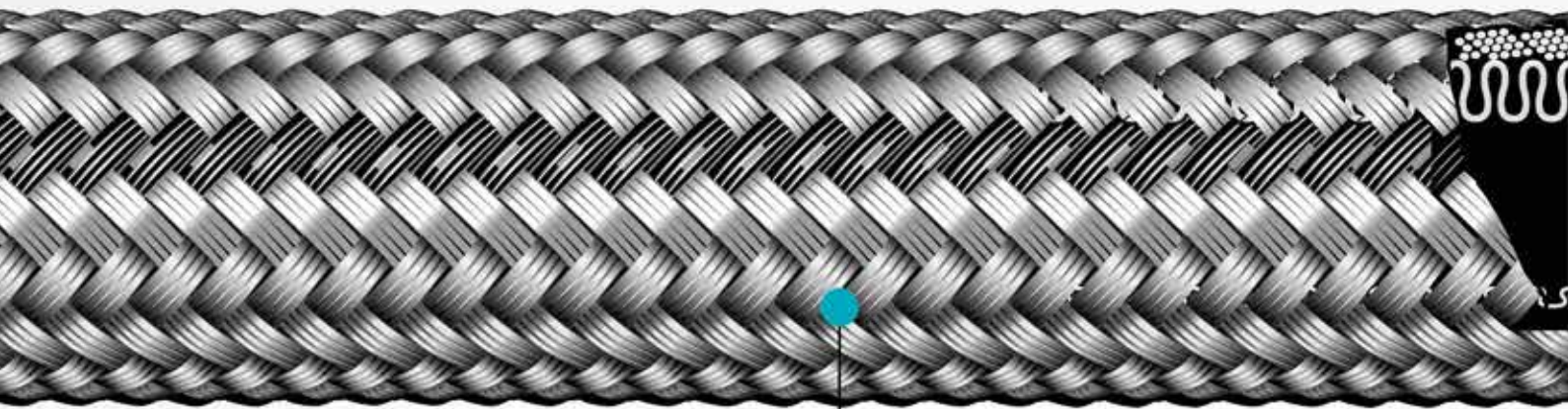

Braid



## FLEXIBLE METAL HOSES INSTALLATION INSTRUCTIONS AND USAGE AREAS

### Inspection

Establish an inspection schedule based on system application and replacement history.

### Electrostatic Discharge

Static electricity can be generated by fluid passing through the hose. Select hose with sufficient conductivity to ground the static electric charge and allow static dissipation. If static electricity generation is possible within an application, choose static dissipative hose and properly ground to earth.

### Vibration

Evaluate amount of system vibration when selecting hose. Metal hose may not be appropriate for systems with constant or severe vibration.

### Length

Take into consideration hose movement, system pressurization, and thermal expansion when determining hose length. Installing hose that does not have sufficient length to accommodate these factors may reduce hose life.

### Minimum Bend Radius

Follow minimum bend radius requirements for your hose. Installing hose with smaller bends may kink hose and reduce hose life.

Hose rupture or leakage may result from bending too close to the hose/fitting connection.

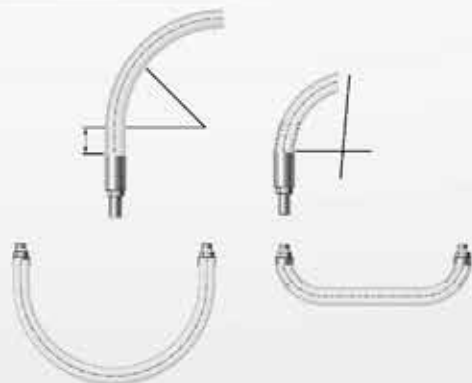

### Hose Strain

Elbows and adapters can be used to relieve hose strain.



### Motion Absorption

Distribute movement and prevent bends smaller than the hose's minimum bend radius by providing sufficient hose length.

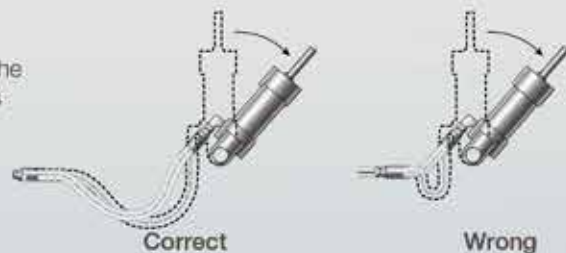

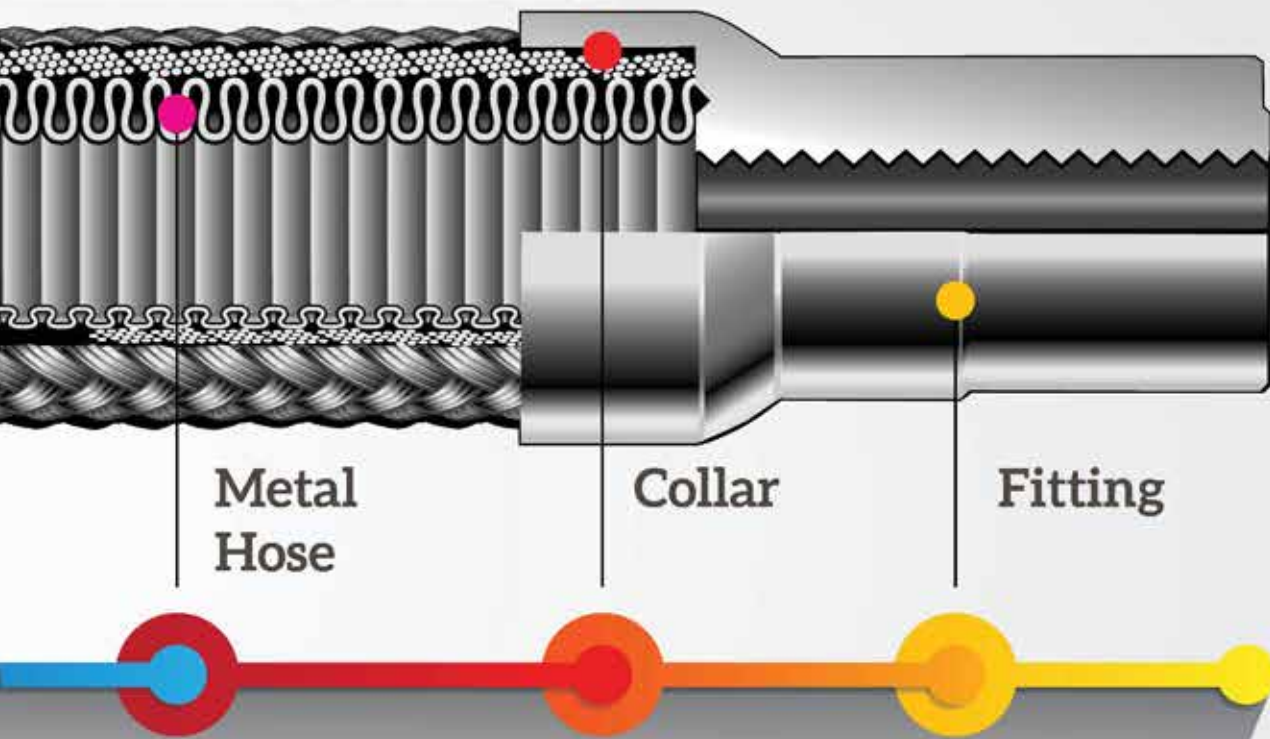

**Machine Tolerance**

Allow for changes in length resulting from machine motion and tolerances.



**System Pressure Changes**

Allow sufficient hose length to accommodate changing system pressures. Do not connect high- and low pressure hoses.

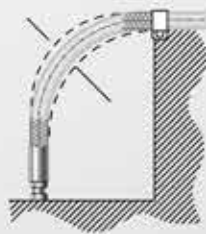

**Bending in One Plane**

Avoid twisting the hose by bending it in one plane only. For a compound bend, use multiple hose pieces or other isolation methods.

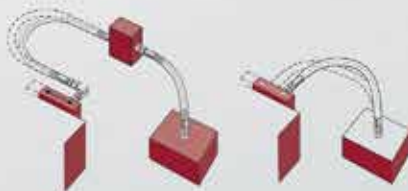

Correct

Wrong

**Correct**

**Wrong**

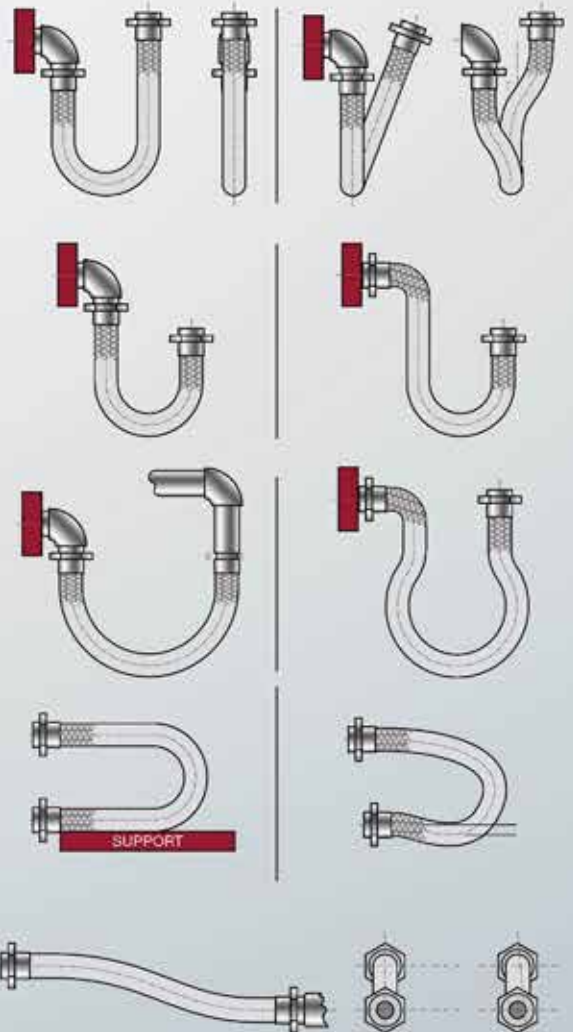

# STANDARD

## Flexible Metal Hoses

Standard flexible metal hoses are long-lasting since they are manufactured from stainless steel.

Standard flexible metal hoses are manufactured as braided and non-braided.

In line with customer demands hoses can be supplied with various type of fittings.

Standard flexible hoses are manufactured in accordance with EN-10380 standard.

### Advantages

- » Long product life
- » Can be used in moving parts
- » Can work at high pressures and temperatures
- » Easy to assemble
- » Hygienic products
- » In line with customer demands, we can manufacture in one piece up to 1.500 meters in desired lengths

### Applications

- » Machinery industry
- » Iron and steel industry
- » Pharmaceutical industry
- » Chemical industry
- » Hot & Cold water pipelines
- » Steam pipelines



## DESIGN VALUES

Without Braid	MH 201 OG
With Braid	MH 201 MG
Hose Material	304, 316L, 321
Braid Material	304, 316L
Working Pressure	0-245 barg
Sizes	DN6-DN50



### 201 OG

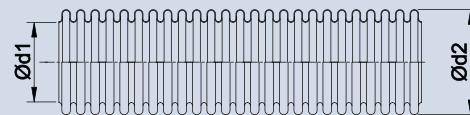

DN		Type	d1	d2	Tolerance	Bending Radius		Working Pressure		Weight (±%10)	Length
						Once-only	Frequent	Permissible Pressure at 20°C (SF3)	Nominal Pressure EN10380 (SF4)		
mm	inch		mm	mm	mm	mm	mm	barg	barg	kg/m	m
6	1/4"	MH 201 OG	6,3	9,6	± 0,2	15	80	24		0,074	10-1000
8	5/16"	MH 201 OG	8,2	12,2	± 0,2	16	125	17		0,087	10-1000
10	3/8"	MH 201 OG	10,3	14,2	± 0,2	18	128	12		0,103	10-1000
12	1/2"	MH 201 OG	12,1	16,7	± 0,2	20	138	9		0,117	10-1000
16	5/8"	MH 201 OG	16,2	21,6	± 0,2	28	160	7		0,177	10-1500
20	3/4"	MH 201 OG	20,3	26,8	± 0,2	32	168	6		0,253	10-1000
25	1"	MH 201 OG	25,3	32,3	± 0,3	40	190	3		0,337	10-600
32	1 1/4"	MH 201 OG	34,3	41,1	± 0,3	50	255	2,5		0,426	10-350
40	1 1/2"	MH 201 OG	40,2	49,8	± 0,3	60	295	2,5		0,706	10-250
50	2"	MH 201 OG	50,3	60,4	± 0,4	70	320	1,6		0,895	10-175

### 201 MG

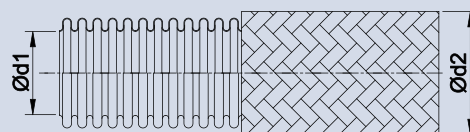

DN		Type	d1	d2	Tolerance	Bending Radius		Working Pressure		Weight (±%10)	Length
						Once-only	Frequent	Permissible Pressure at 20°C (SF3)	Nominal Pressure EN10380 (SF4)		
mm	inch		mm	mm	mm	mm	mm	barg	barg	kg/m	m
6	1/4"	MH 201 MG	6,3	10,8	± 0,2	25	80	245	185	0,160	10-1000
8	5/16"	MH 201 MG	8,2	13,7	± 0,2	32	125	176	132	0,210	10-1000
10	3/8"	MH 201 MG	10,3	15,7	± 0,2	38	128	145	110	0,250	10-1000
12	1/2"	MH 201 MG	12,1	18,1	± 0,2	45	138	93	70	0,275	10-1000
16	5/8"	MH 201 MG	16,2	23,2	± 0,2	58	160	93	70	0,382	10-1500
20	3/4"	MH 201 MG	20,3	28,4	± 0,2	70	168	86	65	0,513	10-1000
25	1"	MH 201 MG	25,3	34,4	± 0,3	85	190	73	55	0,672	10-600
32	1 1/4"	MH 201 MG	34,3	43,2	± 0,3	105	255	60	45	0,915	10-350
40	1 1/2"	MH 201 MG	40,2	52,2	± 0,3	130	295	60	45	1,315	10-250
50	2"	MH 201 MG	50,3	62,7	± 0,4	160	320	40	30	1,610	10-175

# LARGE DIAMETER

## Flexible Metal Hoses

Large diameter hoses are similar to industrial flexible metal hoses in character and are produced between 2 1/2" - 6".

This type of hoses are used for gas and liquid transfer in large industrial facilities, iron and steel factories, cement factories, fuel oil production and storage facilities, gas distribution facilities.

Large diameter hoses are preferred because of their ease of installation in moving parts.

Our company has become a preferred global brand in large diameter hoses due to the possibility of manufacturing as a single piece in lengths of 100mt or more in line with customer demands.

### Advantages

- » Long product life
- » Can be used in moving parts
- » Can work at high pressures and temperatures
- » Easy to assemble
- » Hygienic products
- » In line with customer demands, we can manufacture as a single piece in desired lengths of 100mt or more

### Applications

- » Hydraulic systems
- » High pressure pumps
- » Gas distribution lines
- » Machinery industry
- » Chemical industry





# DESIGN VALUES

Without Braid	MH 301 OG
With Braid	MH 301 MG
Hose Material	304, 316L
Braid Material	304, 316L
Working Pressure	0-25 barg
Sizes	DN65-DN150



## 301 OG

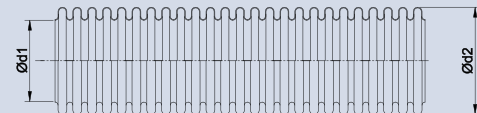

DN		Type	d1	d2	Tolerance	Bending Radius		Working Pressure		Weight (±%10)	Length
						Once-only	Frequent	Permissible Pressure at 20°C (SF3)	Nominal Pressure EN10380 (SF4)		
mm	inch		mm	mm	mm	mm	mm	barg	barg	kg/m	m
65	2 1/2"	MH 301 OG	65,8	77,9	±1,0	110	450	1,2		1,12	5-100
80	3"	MH 301 OG	80,9	95	±1,0	120	520	1		1,5	5-60
100	4"	MH 301 OG	100,2	116,3	± 1,0	165	770	1,4		2,25	5-35
125	5"	MH 301 OG	125,8	144,8	± 1,2	550	1050	0,8		2,6	1-25
150	6"	MH 301 OG	150,0	170	± 1,5	725	1325	0,6		3,2	1-25

## 301 MG

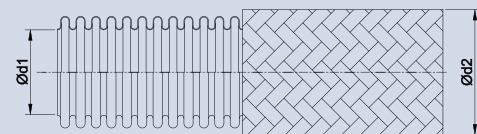

DN		Type	d1	d2	Tolerance	Bending Radius		Working Pressure		Weight (±%10)	Length
						Once-only	Frequent	Permissible Pressure at 20°C (SF3)	Nominal Pressure EN10380 (SF4)		
mm	inch		mm	mm	mm	mm	mm	barg	barg	kg/m	m
65	2 1/2"	MH 301 MG	65,8	81,1	±1,0	205	450	33	25	2,18	5-100
80	3"	MH 301 MG	80,9	98,2	±1,0	235	520	21	16	2,7	5-60
100	4"	MH 301 MG	100,2	119,5	±1,0	295	770	16	12	3,7	5-35
125	5"	MH 301 MG	125,8	148	± 1,2	650	1050	16	12	4,4	1-25
150	6"	MH 301 MG	150,0	173,5	± 1,5	860	1325	8	6	6,2	1-25

# HIGH PRESSURE

## Flexible Metal Hoses

It is our product group that meets the needs of our customers at very high pressures with special braiding designs and due to their larger wall thickness compared to industrial type hoses.

In addition to our standard production from DN6 to DN16, production up to DN50 is made in line with customer demands.

### Advantages

- » Can withstand high pressures without braid
- » Used in moving parts

### Applications

- » Hydraulic systems
- » High pressure pumps
- » Gas distribution lines
- » Machinery industry
- » Chemical industry



## DESIGN VALUES

Without Braid	MH 221 OG
With Braid	MH 221 MG
Hose Material	316L, 321
Braid Material	304, 306
Working Pressure	0-345 barg
Sizes	DN6-DN150

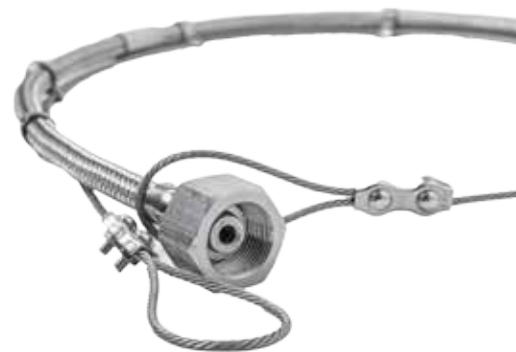

### 221 OG

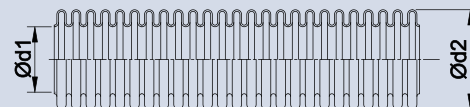

DN		Type	d1	d2	Tolerance	Bending Radius		Working Pressure		Weight ( $\pm 10\%$ )	Length
						Once-only	Frequent	Permissible Pressure at 20°C (SF3)	Nominal Pressure EN10380 (SF4)		
mm	inch		mm	mm	mm	mm	mm	barg	barg	kg/m	m
6	1/4"	MH 221 OG	6,1	10,2	$\pm 0,3$	15	140	43		0,152	10-100
8	5/16"	MH 221 OG	8,1	12,9	$\pm 0,3$	20	180	50		0,213	10-100
10	3/8"	MH 221 OG	10,1	16,1	$\pm 0,3$	25	220	33		0,225	10-100
12	1/2"	MH 221 OG	12,1	18,8	$\pm 0,3$	30	250	32		0,375	10-100
16	5/8"	MH 221 OG	16,2	24,5	$\pm 0,3$	40	300	22		0,585	10-100

### 221 MG

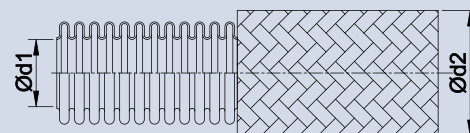

DN		Type	d1	d2	Tolerance	Bending Radius		Working Pressure		Weight ( $\pm 10\%$ )	Length
						Once-only	Frequent	Permissible Pressure at 20°C (SF3)	Nominal Pressure EN10380 (SF4)		
mm	inch		mm	mm	mm	mm	mm	barg	barg	kg/m	m
6	1/4"	MH 221 MG	6,1	11,6	$\pm 0,3$	25	140	345	255	0,257	10-100
8	5/16"	MH 221 MG	8,1	14,5	$\pm 0,3$	32	180	265	200	0,365	10-100
10	3/8"	MH 221 MG	10,1	17,6	$\pm 0,3$	38	220	220	165	0,470	10-100
12	1/2"	MH 221 MG	12,1	20,4	$\pm 0,3$	45	250	186	140	0,595	10-100
16	5/8"	MH 221 MG	16,2	26,5	$\pm 0,3$	58	300	186	140	0,945	10-100

# SOLAR

## Flexible Metal Hoses

Solar-type hoses are products with more open pitch than standard type hoses.

They are lighter than standard hoses. They have a high surface area for excellent heat transfer.

Due to the use of 316L stainless steel, it can be used in drinking water, food production and hygiene needs.

In line with customer demands, 10mt.-20mt.- 25mt.- 50mt.-100mt. such as desired lengths, or It can be shipped with reels up to 1500mt.

### Advantages

- » Easy installation with its flexible body and screwed fittings
- » Lightweight and easy to transport
- » Large surface areas
- » Excellent heat transfer properties
- » Can be supplied in one long piece lengths
- » Applicable to heat pump and hybrid systems

### Applications

- » Solar energy systems
- » Static usage areas
- » Hot & Cold water pipelines

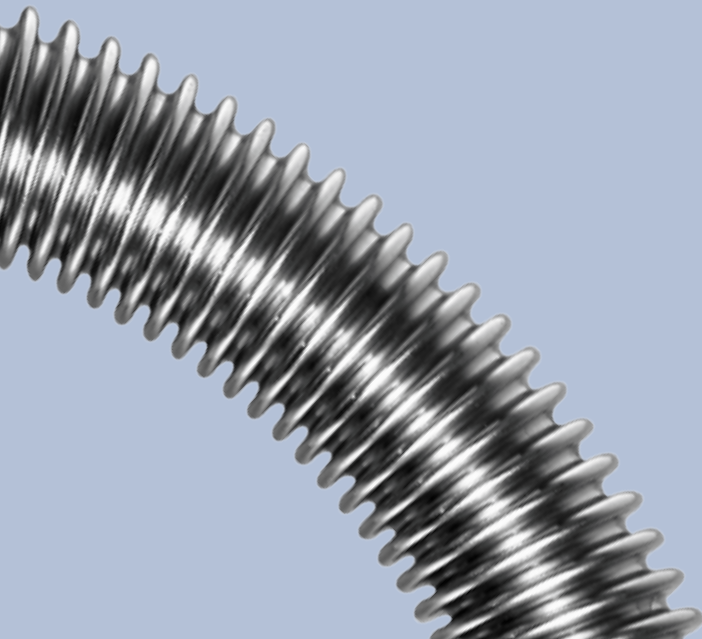

## DESIGN VALUES

Without Braid	MH 211 OG
Hose Material	304, 316L, 321
Working Pressure	0-21 barg
Sizes	DN12-DN50



## 211 OG

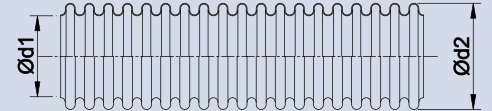

DN		Type	d1	d2	Tolerance	Bending Radius	Working Pressure at 20°C	Surface Area	Weight	Length
mm	inch		mm	mm	mm	mm	barg	m <sup>2</sup> /m	kg/m	m
12	1/2"	MH 211 OG	12,4	16,5	± 0,3	20	21	0,072	0,085	10-100
16	5/8"	MH 211 OG	16,3	21,4	± 0,3	25	16	0,096	0,136	10-100
20	3/4"	MH 211 OG	20,4	26,7	± 0,3	30	10	0,136	0,192	10-100
25	1"	MH 211 OG	25,4	31,9	± 0,4	35	10	0,174	0,273	10-100
32	1 1/4"	MH 211 OG	34,5	41,1	± 0,4	40	4	0,203	0,35	10-100
40	1 1/2"	MH 211 OG	40,5	49,6	± 0,4	50	4	0,285	0,56	10-100
50	2"	MH 211 OG	50,7	60,1	± 0,4	60	3	0,35	0,686	10-100

# BOILER

## Flexible Metal Hoses

Profile of the boiler hoses is similar to solar hoses, but the wall thickness is larger.

These hoses have a longer life at high pressures due to their high wall thickness.

It is used in the manufacture of heat exchangers, especially boilers.

### Advantages

- » Large surface areas
- » High heat transfer efficiency
- » Can be supplied in one long piece lengths
- » Heating surface without calcification for heating
- » High acid and corrosion resistance with its stainless steel body
- » Can be installed easily different boiler type with its flexible body

### Applications

- » Boiler systems
- » Heat Pumps
- » Hot & Cold water pipelines



## DESIGN VALUES

Without Braid	MH 211 K
Hose Material	316L
Fittings Material	304, 316L
Working Pressure	0-10 barg
Sizes	DN20-DN40



## 211 K

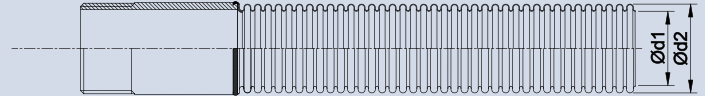

DN		Type	d1	d2	Tolerance	Working Pressure at 20°C	Surface Area	Weight	Length
mm	inch		mm	mm					
20	3/4"	MH 211 K	20,4	26,7	± 0,3	16	0,130	0,305	10-100
25	1"	MH 211 K	25,4	31,9	± 0,4	12	0,191	0,382	10-100
32	1 1/4"	MH 211 K	34,5	41,1	± 0,4	10	0,221	0,553	10-100
40	1 1/2"	MH 211 K	40,5	49,6	± 0,4	10	0,255	0,800	10-100

# HT COMPOSITE

## Pre-Insulated Hoses

Insulated hoses are used for fluid transfer at high temperatures. Form of these hoses is the same as solar hoses and they contain three layers of insulation.

Fireproof inner layer protects the other layers of the insulation from high temperatures, middle layer prevents heat transfer due to its closed cell structure, and the UV coating on the outer layer protects the product from external effects, sunlight, adverse weather conditions and damage caused by animals such as mice and birds.

### Advantages

- » Insulated hoses can be used at high temperature resistant inside layer
- » Weather and UV resistant protective outer layer
- » Easy assembly
- » Middle layer of standart crosslinked PE insulation

### Applications

- » It is generally used in the transfer of liquid fluid between solar panels and heat pumps

### DESIGN VALUES

Without Braid	MH 211 OG
Hose Material	316L
Insulation Material	Composite
Working Pressure	0-21 barg
Sizes	DN12-DN25

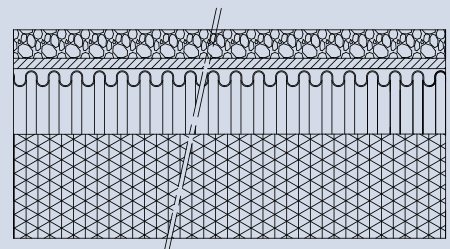
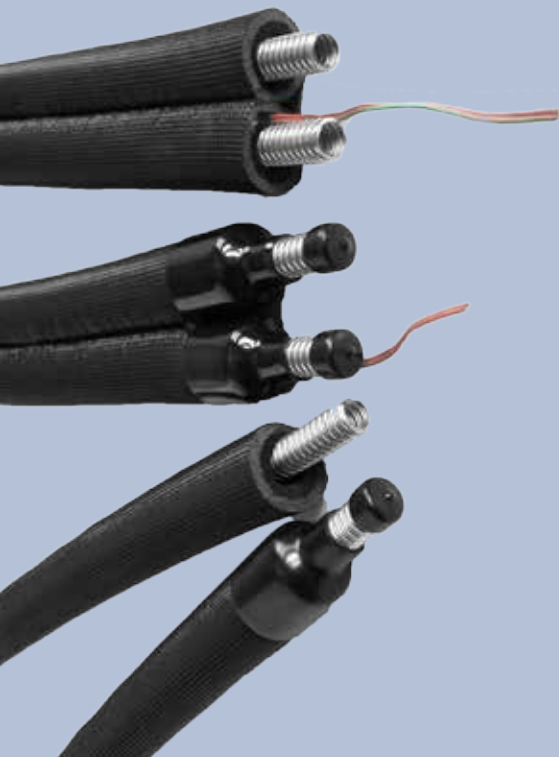



# HEAT EXCHANGER

## Coils

These product are designed according to customer requests.

Hose shape is similar to solar hose and boiler hose.

This product group is ready-to-install products.

They create cost advantages for manufacturers due to their easy assembly.

### Advantages

- » Complete heat exchanger
- » Coil with frame tailor made according to customer specifications
- » Easy assembly

### Applications

- » Boiler systems
- » Heat pumps
- » Hot & Cold water pipelines
- » Air fin coolers
- » Air dryer
- » Heat exchanger
- » Cooling systems

### DESIGN VALUES

Without Braid	MH 211 K
Hose Material	316L
Fittings Material	304, 316L
Wire Material	304
Working Pressure	0-21 barg
Sizes	DN6-DN50

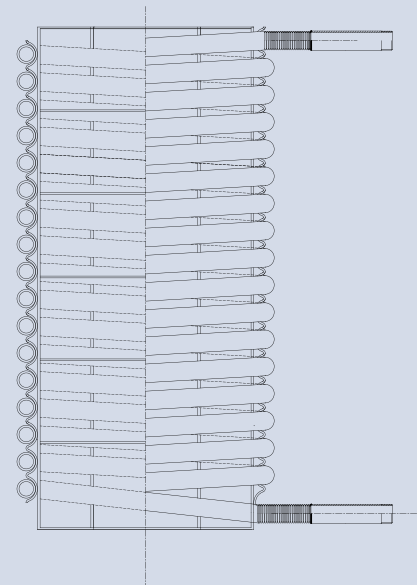

# DISTRICT HEATING

## Flexible Metal Hoses

These products are specially designed for district heating systems.

Wall thickness is considerably higher than of standard hoses.

They are used in the transfer of high temperature fluids.

### Advantages

- » High temperature resistant inside layer
- » Middle layer of standart crosslinked PUR insulation
- » Weather and UV resistant protective outer layer

### Applications

- » District heating systems
- » High temperature fluid transfer lines



## DESIGN VALUES

Without Braid	DH
Hose Material	304, 316L
Working Pressure	0-21 barg
Sizes	DN30-DN150



## 211 K

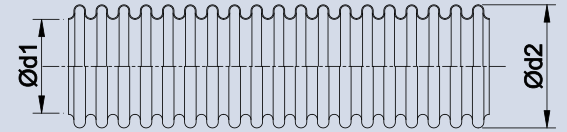

DN	Type	d1	d2	Tolerance	Bending Radius	Wall Thickness	Weight
mm		mm	mm	mm	mm	mm	kg/m
30	DH30	29	34	± 1	200	0,3	0,4
40	DH40	39	44	± 1	200	0,4	0,7
50	DH50	48	55	± 1	250	0,5	1,3
60	DH60	60	66	± 2	300	0,5	1,5
76	DH76	76	85	± 2	400	0,6	2,4
90	DH90	88	98	± 2	450	0,7	3,5
100	DH100	98	109	± 2	600	0,8	4,5
110	DH110	109	119	± 2	650	0,8	4,7
125	DH125	127	139	± 2	800	0,8	5,8
150	DH150	144	156	± 2	950	0,9	7,7

# FAN COIL

## Flexible Connectors

These products are designed according to customer requests.

Hose shape is similar to solar hose.

This product group is ready-to-install products.

They create cost advantages for manufacturers due to easy assembly.

### **Advantages**

- » Fan-coil connectors are used for flexible connections of fan-coil units to the heating / cooling system distribution piping
- » They are easy to assemble

### **Applications**

- » Fan-coil units
- » Heating / cooling system

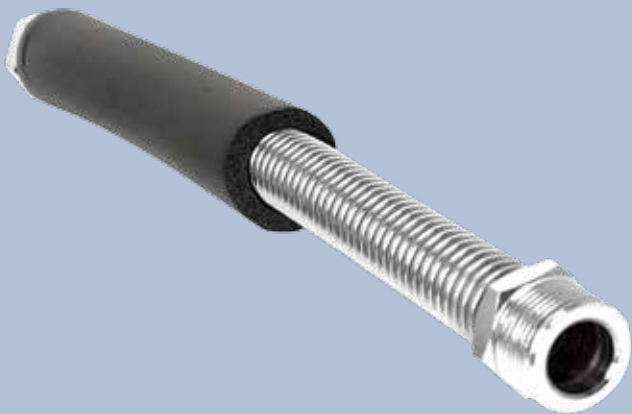

# DESIGN VALUES

Without Braid	MH 201 OG, MH 211 OG
With Braid	MH 201 MG
Hose Material	304, 316L
Braid Material	304
Working Pressure	0-21 barg
Sizes	DN12-DN50



## 201 OG

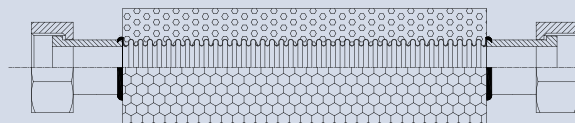

DN		Type	d1	d2	Tolerance	Fitting 1	Fitting 2	Insulation Thickness	Length
mm	inch		mm	mm					
DN12	1/2"	201 OG	12,1	16,7	±0,2	1/2" Male	1/2" Male	13	200-300-400-500-600-700-800-900-1000
DN12	1/2"	201 OG	12,1	16,7	±0,2	1/2" Male	1/2" Female	13	200-300-400-500-600-700-800-900-1000
DN16	5/8"	201 OG	16,2	21,6	±0,2	3/4" Male	3/4" Male	13	200-300-400-500-600-700-800-900-1000
DN16	5/8"	201 OG	16,2	21,6	±0,2	3/4" Male	3/4" Female	13	200-300-400-500-600-700-800-900-1000
DN20	3/4"	201 OG	20,3	26,8	±0,2	1" Male	1" Male	13	200-300-400-500-600-700-800-900-1000
DN20	3/4"	201 OG	20,3	26,8	±0,2	1" Male	1" Female	13	200-300-400-500-600-700-800-900-1000
DN25	1"	201 OG	25,3	32,3	±0,3	1 1/4" Male	1 1/4" Male	13	200-300-400-500-600-700-800-900-1000
DN25	1"	201 OG	25,3	32,3	±0,3	1 1/4" Male	1 1/4" Female	13	200-300-400-500-600-700-800-900-1000

## 201 MG

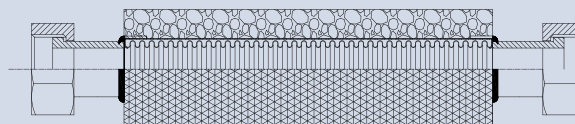

DN		Type	d1	d2	Tolerance	Fitting 1	Fitting 2	Insulation Thickness	Length
mm	inch		mm	mm					
DN12	1/2"	201 MG	12,1	18,1	±0,2	1/2" Male	1/2" Male	13	200-300-400-500-600-700-800-900-1000
DN12	1/2"	201 MG	12,1	16,7	±0,2	1/2" Male	1/2" Female	13	200-300-400-500-600-700-800-900-1000
DN16	5/8"	201 MG	16,2	23,2	±0,2	3/4" Male	3/4" Male	13	200-300-400-500-600-700-800-900-1000
DN16	5/8"	201 MG	16,2	23,2	±0,2	3/4" Male	3/4" Female	13	200-300-400-500-600-700-800-900-1000
DN20	3/4"	201 MG	20,3	28,4	±0,2	1" Male	1" Male	13	200-300-400-500-600-700-800-900-1000
DN20	3/4"	201 MG	20,3	28,4	±0,2	1" Male	1" Female	13	200-300-400-500-600-700-800-900-1000
DN25	1"	201 MG	25,3	34,4	±0,3	1 1/4" Male	1 1/4" Male	13	200-300-400-500-600-700-800-900-1000
DN25	1"	201 MG	25,3	34,4	±0,3	1 1/4" Male	1 1/4" Female	13	200-300-400-500-600-700-800-900-1000

# ULTRA FLEXIBLE

## Flexible Metal Hoses

Ultra flexible metal hoses are made of stainless steel, so they are long-lasting.

Ultra flexible hoses are products with closer pitch than standard type hoses making them ultra flexible.

Ultra flexible metal hoses are manufactured as braided and non-braided as standard.

In line with customer demands, they can be supplied with fittings on ends.

Ultra flexible hoses are manufactured in accordance with EN-10380 ultra flexible metal hoses.

### Advantages

- » Long product life
- » Can be used in moving parts
- » Can work at high pressures and temperatures
- » Easy to assemble
- » Hygienic products

### Applications

- » Machinery industry
- » Iron and steel industry
- » Pharmaceutical industry
- » Chemical industry
- » Hot & Cold water pipelines
- » Steam pipelines



# DESIGN VALUES

Without Braid	MH 231 OG
With Braid	MH 231 MG
Hose Material	304, 316L, 321
Braid Material	304, 316L
Working Pressure	0-145 barg
Sizes	DN6-DN80



## 231 OG

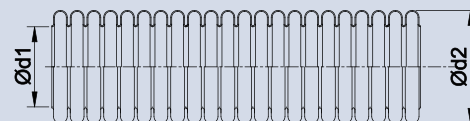

DN		Type	d1	d2	tolerance	Bending Radius		Working Pressure		Weight	Length
						Once-only	Frequent	Permissible Pressure at 20°C (SF3)	Nominal Pressure EN10380 (SF4)		
mm	inch		mm	mm	mm	mm	mm	barg	barg	kg/m	m
6	1/4"	MH 231 OG	6,4	10,5	± 0,2	13	70	24		0,096	10-1000
8	5/16"	MH 231 OG	8,5	12,4	± 0,2	15	95	17		0,115	10-1000
10	3/8"	MH 231 OG	10,3	14,5	± 0,2	15	95	10		0,145	10-1000
12	1/2"	MH 231 OG	12,4	16,7	± 0,2	20	105	8		0,155	10-1000
16	5/8"	MH 231 OG	16,2	22,0	± 0,2	25	120	6		0,230	10-1500
20	3/4"	MH 231 OG	20,2	27,0	± 0,2	32	130	4		0,390	10-1000
25	1"	MH 231 OG	25,1	32,0	± 0,3	40	150	4		0,490	10-600
32	1 1/4"	MH 231 OG	34,3	41,1	± 0,3	50	200	2,5		0,600	10-350
40	1 1/2"	MH 231 OG	40,0	49,9	± 0,4	60	220	1		0,990	10-250
50	2"	MH 231 OG	50,9	60,5	± 0,4	70	240	1		1,160	10-175
65	2 1/2"	MH 331 OG	66,5	78,2	±1,0	120	340	1		1,45	5-100
80	3"	MH 331 OG	82,5	96,5	±1,0	150	400	1		1,95	5-60

## 231 MG

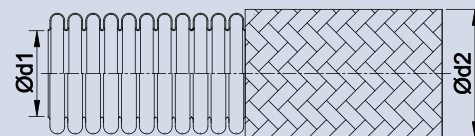

DN		Type	d1	d2	tolerance	Bending Radius		Working Pressure		Weight	Length
						Once-only	Frequent	Permissible Pressure at 20°C (SF3)	Nominal Pressure EN10380 (SF4)		
mm	inch		mm	mm	mm	mm	mm	barg	barg	kg/m	m
6	1/4"	MH 231 MG	6,4	11,7	± 0,2	23	70	145	110	0,190	10-1000
8	5/16"	MH 231 MG	8,5	13,7	± 0,2	30	95	133	100	0,236	10-1000
10	3/8"	MH 231 MG	10,3	16,1	± 0,2	35	95	105	80	0,275	10-1000
12	1/2"	MH 231 MG	12,4	18,4	± 0,2	40	105	105	80	0,280	10-1000
16	5/8"	MH 231 MG	16,2	23,2	± 0,2	45	120	105	80	0,440	10-1500
20	3/4"	MH 231 MG	20,2	28,4	± 0,2	60	130	86	65	0,650	10-1000
25	1"	MH 231 MG	25,1	34,4	± 0,3	80	150	73	55	0,765	10-600
32	1 1/4"	MH 231 MG	34,3	43,2	± 0,3	105	200	60	45	1,070	10-350
40	1 1/2"	MH 231 MG	40,0	51,8	± 0,4	130	220	53	40	1,550	10-250
50	2"	MH 231 MG	50,9	62,7	± 0,4	160	240	40	30	1,810	10-175
65	2 1/2"	MH 331 MG	66,5	80,7	±1,0	190	340	25	16	2,50	5-100
80	3"	MH 331 MG	82,5	99,0	±1,0	250	400	13	10	3,00	5-60

# ANNEALED

## Flexible Metal Hoses

This type of hose is annealed after forming to eliminate the cold working effects of the forming process. These hoses keep their shape when bent.

The hose profile similar to solar hose. These hoses are preferred because they are easy to assemble. There is no need to use elbow, reductions or other parts during assembly. Not need cutting, threading, welding and so on during assembly.

Annealed flexible metal hoses are manufactured in accordance with EN-15266 standart.

### Advantages

- » Easy to assemble
- » Takes desired shape easily
- » Keeps its shape when bent
- » Saves Money and time.
- » It reduces the risk of leakage since it is monolithic.
- » Not required a lot of extra part for assembly.

### Applications

- » Gas pipelines
- » Hot & Cold water pipelines





## DESIGN VALUES

Without Braid	MH 211
Hose Material	304, 316L, 321
Working Pressure	0-21 barg
Sizes	DN12-DN50



## 211

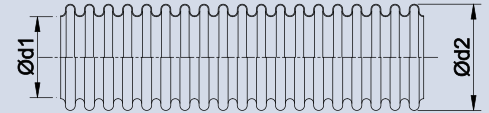

DN		Type	d1	d2	tolerance	Bending Radius	Working Pressure at 20°C	Surface Area	Weight	Length
mm	inch		mm	mm	mm	mm	barg	m <sup>2</sup> /m	kg/m	m
12	1/2"	MH 211	12,4	16,5	± 0,3	20	21	0,072	0,085	10-100
16	5/8"	MH 211	16,3	21,4	± 0,3	25	16	0,096	0,136	10-100
20	3/4"	MH 211	20,4	26,7	± 0,3	30	10	0,136	0,192	10-100
25	1"	MH 211	25,4	31,9	± 0,4	35	10	0,174	0,273	10-100
32	1 1/4"	MH 211	34,5	41,1	± 0,4	40	4	0,203	0,35	10-100
40	1 1/2"	MH 211	40,5	49,6	± 0,4	50	4	0,285	0,56	10-100
50	2"	MH 211	50,7	60,1	± 0,4	60	3	0,35	0,686	10-100

# COPPER FITTINGS

## Flexible Metal Hoses

Hose profile similar to standard hose profile.

They can easily be connected to a copper pipe with silver welding.

This type of hoses is used in water pipelines and plumbing.

Silver welding is used for attaching the hose to copper end connections.

### Advantages

- » Quick connection
- » Easy installation
- » Easily replaced
- » Can be restrained
- » Lower over all length with respect to weld end expansion joints

### Applications

- » Hot & Cold water pipelines
- » Heat pump system
- » Boiler system
- » Plumbing



## DESIGN VALUES

Without Braid	201 OG
PN	0-5
Hose Material	304, 316L, 321
Fittings Material	Copper
Sizes	DN6-DN50



## 201

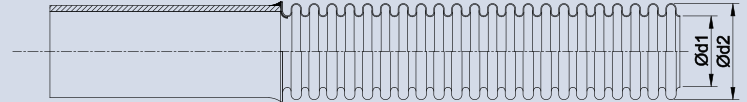

DN		Type	d1	d2	Tolerance	Copper Pipe 1	Copper Pipe 2	Length
mm	inch		mm	mm		mm	mm	
DN6	1/4"	201 OG	6,3	9,6	±0,2	8x1	8x1	400-600-800-1000-1200-1500-2000
DN8	5/16"	201 OG	8,2	12,2	±0,2	8x1	8x1	400-600-800-1000-1200-1500-2000
DN10	3/8"	201 OG	10,3	14,2	±0,2	12x1	12x1	400-600-800-1000-1200-1500-2000
DN12	1/2"	201 OG	12,1	16,7	±0,2	12x1	12x1	400-600-800-1000-1200-1500-2000
DN12	1/2"	201 OG	12,1	16,7	±0,2	12x1	15x1	400-600-800-1000-1200-1500-2000
DN12	1/2"	201 OG	12,1	16,7	±0,2	15x1	15x1	400-600-800-1000-1200-1500-2000
DN16	5/8"	201 OG	16,2	21,6	±0,2	15x1	15x1	400-600-800-1000-1200-1500-2000
DN16	1/2"	201 OG	16,2	21,6	±0,2	22x1	15x1	400-600-800-1000-1200-1500-2000
DN16	1/2"	201 OG	16,2	21,6	±0,2	22x1	22x1	400-600-800-1000-1200-1500-2000

# CUT & FIT

## Tool Kit

All the tools you need to connect hoses to existing installations or to extend hoses are included in this kit.

This tool is easy to carry due to its light weight.

This tool kit does not need power tools or external power source.

Nipple, nut, ring, gasket and compulsion tool included in this kit.

### Advantages

- » Quick connection
- » Easy installation
- » No need for external power source

### Applications

- » Hot & Cold water pipelines
- » Solar energy systems
- » Heat pump systems
- » Boiler systems



# CONTENTS

Gasket Material	Compressed non-asbestos fibre
Ring Material	304
Nut Material	Brass
Nipple Material	Brass

DN		Hose	Segment	Gasket	Nut	Nipple	Reduction	Compression Tool	Compression Tool Collet
mm	inch								
6	1/4"	1/4"	1/4"	1/4"	1/4"	1/4"	-	TYPE 1	DN6-DN6 / DN6-DN8
8	5/16"	5/16"	5/16"	5/16"	5/16"	5/16"	5/16" - 1/4"	TYPE 1	DN8-DN8 / DN8-DN10
10	3/8"	3/8"	3/8"	3/8"	3/8"	3/8"	3/8" - 5/16"	TYPE 1	DN10-DN10 / DN10-DN12
12	1/2"	1/2"	1/2"	1/2"	1/2"	1/2"	1/2" - 3/8"	TYPE 1	DN12-DN12 / DN12-DN16
16	5/8"	5/8"	3/4"	3/4"	3/4"	3/4"	3/4" - 1/2"	TYPE 1	DN16-DN16 / DN16-DN20
20	3/4"	3/4"	1"	1"	1"	1"	1" - 3/4"	TYPE 1	DN20-DN20 / DN20-DN25
25	1"	1"	1 1/4"	1 1/4"	1 1/4"	1 1/4"	1 1/4" - 1"	TYPE 1	DN25-DN25 / DN25-DN32
32	1 1/4"	1 1/4"	1 1/2"	1 1/2"	1 1/2"	1 1/2"	1 1/2" - 1 1/4"	TYPE 2	DN32-DN32 / DN32-DN40
40	1 1/2"	1 1/2"	2"	2"	2"	2"	2" - 1 1/2"	TYPE 2	DN40-DN40

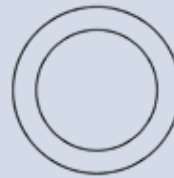
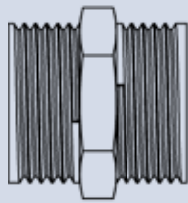
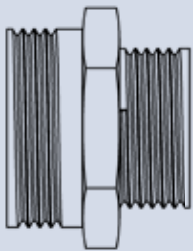

# EXPANSION JOINTS PART NUMBER DESCRIPTIONS

## Code Example

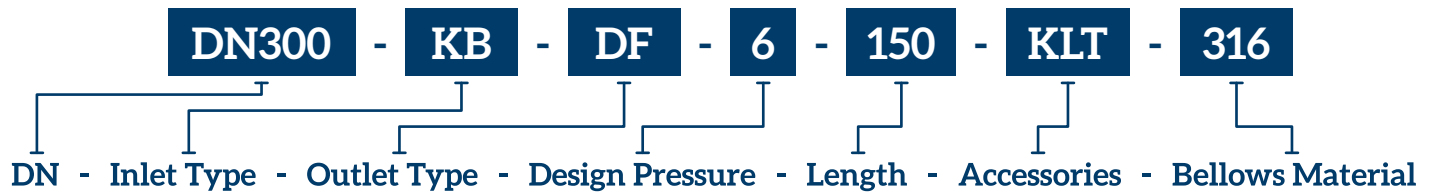

DN

Nominal Diameter

Length

Total length of expansion joint

Inlet  
Type

KB - Weld end  
SF - Fixed Flange  
DF - Rotating Flange  
DB - Externally Pressurized  
U - Universal  
SP - Special

Accessories

H - Hinged  
K - Outer Cover  
R - Limit Rod  
E - Elbow Pressure Balanced  
G - Gimbal  
I - Inline Pressure Balanced  
L - Liner (Inner Sleeve)  
T - Tie Rod

Outlet  
Type

KB - Weld end  
SF - Fixed Flange  
DF - Rotating Flange  
DB - Externally Pressurized  
U - Universal  
SP - Special

Bellows  
Material

304/304L  
316/316L  
321  
309S  
310S  
INC625-Alloy625  
904L  
2205-DUPLEX 2205  
Etc.

Design  
Pressure

Pressure which will be used  
for design

# FLEXIBLE METAL HOSES PART NUMBER DESCRIPTIONS

## Code Example

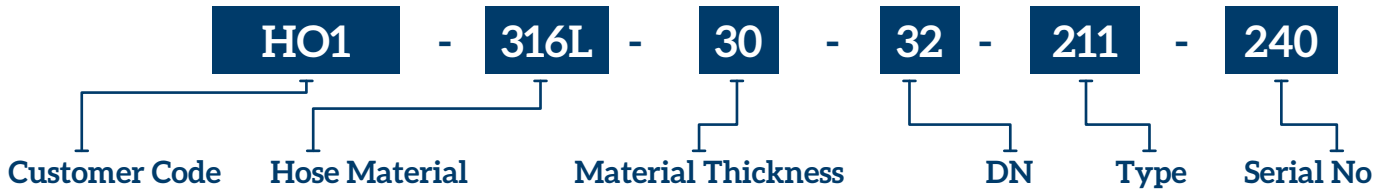

Customer Code	H01 H02 ... H998 H999	DN	<table border="0"> <tr><td>6</td><td>25</td><td>100</td></tr> <tr><td>8</td><td>32</td><td>125</td></tr> <tr><td>10</td><td>40</td><td>150</td></tr> <tr><td>12</td><td>50</td><td></td></tr> <tr><td>16</td><td>65</td><td></td></tr> <tr><td>20</td><td>80</td><td></td></tr> </table>	6	25	100	8	32	125	10	40	150	12	50		16	65		20	80							
6	25	100																									
8	32	125																									
10	40	150																									
12	50																										
16	65																										
20	80																										
Hose Material	316L 321 304	Serial No	001 002 ..... 999																								
Material Thickness	<table border="0"> <tr><td>15-0,15mm.</td><td>40-0,40mm.</td></tr> <tr><td>18-0,18mm.</td><td>50-0,50mm.</td></tr> <tr><td>20-0,20mm.</td><td>60-0,60mm.</td></tr> <tr><td>22-0,22mm.</td><td>70-0,70mm.</td></tr> <tr><td>25-0,25mm.</td><td>80-0,80mm.</td></tr> <tr><td>30-0,30mm.</td><td>90-0,90mm.</td></tr> </table>			15-0,15mm.	40-0,40mm.	18-0,18mm.	50-0,50mm.	20-0,20mm.	60-0,60mm.	22-0,22mm.	70-0,70mm.	25-0,25mm.	80-0,80mm.	30-0,30mm.	90-0,90mm.												
15-0,15mm.	40-0,40mm.																										
18-0,18mm.	50-0,50mm.																										
20-0,20mm.	60-0,60mm.																										
22-0,22mm.	70-0,70mm.																										
25-0,25mm.	80-0,80mm.																										
30-0,30mm.	90-0,90mm.																										
Type	<table border="0"> <tr><td>201 OG</td><td>Standard Hoses Without Braid</td></tr> <tr><td>201 MG</td><td>Standard Hoses With Braid</td></tr> <tr><td>211 OG</td><td>Solar Hoses</td></tr> <tr><td>211 K</td><td>Boiler Hoses</td></tr> <tr><td>221 OG</td><td>High Pressure Hoses With Braid</td></tr> <tr><td>221 MG</td><td>High Pressure Hoses Without Braid</td></tr> <tr><td>231 OG</td><td>Ultra Flexible Hoses Without Braid</td></tr> <tr><td>231 MG</td><td>Ultra Flexible Hoses With Braid</td></tr> <tr><td>301 OG</td><td>Large Diameter Hoses Without Braid</td></tr> <tr><td>301 MG</td><td>Large Diameter Hoses With Braid</td></tr> <tr><td>331 OG</td><td>Ultra Flexible Large Diameter Hoses Without Braid</td></tr> <tr><td>331 MG</td><td>Ultra Flexible Large Diameter Hoses With Braid</td></tr> </table>			201 OG	Standard Hoses Without Braid	201 MG	Standard Hoses With Braid	211 OG	Solar Hoses	211 K	Boiler Hoses	221 OG	High Pressure Hoses With Braid	221 MG	High Pressure Hoses Without Braid	231 OG	Ultra Flexible Hoses Without Braid	231 MG	Ultra Flexible Hoses With Braid	301 OG	Large Diameter Hoses Without Braid	301 MG	Large Diameter Hoses With Braid	331 OG	Ultra Flexible Large Diameter Hoses Without Braid	331 MG	Ultra Flexible Large Diameter Hoses With Braid
201 OG	Standard Hoses Without Braid																										
201 MG	Standard Hoses With Braid																										
211 OG	Solar Hoses																										
211 K	Boiler Hoses																										
221 OG	High Pressure Hoses With Braid																										
221 MG	High Pressure Hoses Without Braid																										
231 OG	Ultra Flexible Hoses Without Braid																										
231 MG	Ultra Flexible Hoses With Braid																										
301 OG	Large Diameter Hoses Without Braid																										
301 MG	Large Diameter Hoses With Braid																										
331 OG	Ultra Flexible Large Diameter Hoses Without Braid																										
331 MG	Ultra Flexible Large Diameter Hoses With Braid																										



---

KLINGER Turkey Esnek Bağlantı Elemanları  
San. ve Tic. A.Ş.

İst. E.T. Serbest Bölgesi 6. Sokak No:111  
34957 Tuzla - İstanbul / TURKEY

T: +90 216 540 19 49 » F: +90 216 314 36 16

[www.klingerturkey.com](http://www.klingerturkey.com)