

Air Vents

Armstrong

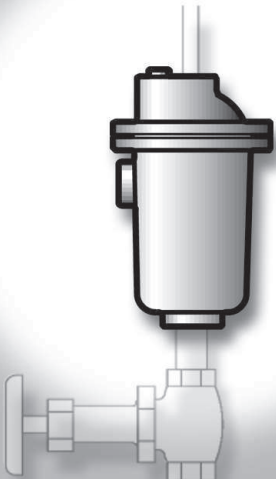



Air Vent ID Charts

Table AV-394-1. Armstrong Air Vents																		
Illustration	Type	Flow Direction	Connection Type	Max. Allow. Press. barg	TMA °C	Body Material	Model	Max. Oper. Press. barg	Connection Size							Located on Page		
									1/8"	1/4"	1/2"	3/4"	1"	1 1/2"	2"			
	Series 1-AVCW See-thru Free Floating Lever Air Vents for Ozone Applications	→ ↑	Screwed	10	66	PBT Cap (Polybutylene Terephthalate) Polysulfone Body	1-AVCW	10			▲	★★					AV-410	
	Series 1-AVC See-Thru Free Floating Lever Air/Gas Vents	→ ↑	Screwed	10	66	Nylon Cap Polysulfone Body	1-AVC	10			●	★★					AV-396	
	Series 21-AR Fixed Pivot Ball Float Air/Gas Vents	↑	Screwed	17	232	ASTM A48 Class 30 Cast Iron	21-AR	17			●	●					AV-397	
	Series 21-312 Fixed Pivot Ball Float Air/Gas Vents	→ ↑	Screwed Socketweld Flanged †††	41 or 34	38 or 399	ASTM A105 Forged Steel	21-312AR 21-312VAR	4,5 41			●	●					AV-397	
	Series 1, 2, 3, 6 Free Floating Lever Air/Gas Vents	→ ↑	Screwed Flanged †††	21	93	ASTM A48 Class 30 Cast Iron	1-AV †	21			★	★					AV-398	
				17	232		2-AV 3-AV 6-AV	17			●	●	●	●	●			
	Series 30 Free Floating Lever Air/Gas Vents	→ ↑	Screwed Socketweld Flanged †††	41 or 34	38 or 399	ASTM A105 Forged Steel	32-AV	41			●	●					AV-400	
				69 or 41	38 or 399		33-AV	62			●	●	●					
				69 or 41	38 or 399		36-AV	69						●	●			
	Series 10 Free Floating Lever Air/Gas Vents	→ ↑	Screwed Socketweld (22 and 13 only) Flanged †††	34 or 30	38 or 260	304-L Stainless Steel	11-AV ††	28			●	★★					AV-404	
				38 or 33	38 or 260		22-AV	38				●						
				39 or 34	238 or 260		13-AV	39						●				
	Series HLAR High Leverage Air/Gas Vents	→ ↑	Screwed Socketweld Flanged †††	69 or 41	38 or 399	ASTM A105 Forged Steel	2313 HLAR	69			●	●	●				AV-402	
							2315 HLAR							●	1 1/4" ● 1 1/2" ●			
							2316 HLAR								●	●		
	Series HLAR High Leverage Air/Gas Vents	→ ↑	Screwed Socketweld Flanged †††	103 or 62	38 or 454	ASTM A182 Gr. F22 Forged Steel	2413 HLAR	103			●	●	●				AV-402	
				125 or 62	38 or 482		2415 HLAR	124					●	1 1/4" ● 1 1/2" ●				
							2416 HLAR	103						●	●			

★ 1/4" outlet connection ★★ 1/2" outlet connection † Side connection available ▲ Alternate inlet 1/2"
 †† Side connection not available ††† Flange selection may limit pressure and temperature rating.

Air Vent ID Charts



Table AV-395-1. Armstrong Air Vents																	
Illustration	Type	Flow Direction	Connection Type	Max. Allow. Press. barg	TMA °C	Body Material	Model	Max. Oper. Press. barg	Connection Size							Located on Page	
									1/8"	1/4"	1/2"	3/4"	1"	1 1/2"	2"		
	Series HLAR High Leverage Air/Gas Vents		Screwed Socketweld Flanged †††	146 or 117	38 or 482	ASTM A182 Gr. F22 Forged Steel	25133G-HLAR	146			•	•	•				AV-402
				174 or 138	38 or 482		25155G-HLAR	172				•	•	•			
				255 or 207	38 or 482		26155G-HLAR	186						•	•		
	Series TTF Thermostatic Air Vents		Straight-Thru Right Angle	20	232	304-L Stainless Steel	TTF-1 TTF-1R	21			•	•					AV-406
	TAVB Thermostatic Bellows with Integral Vacuum Breaker		Straight-Thru Screwed	20	232	304L Stainless Steel	TAVB-2 TAVB-3	10			•						AV-407
	Series TV-2 Thermostatic Air Vents		Screwed	9	177	ASTM B62 Cast Bronze	TV-2	8,5			•						AV-409
	Series TS-2 Thermostatic Air Vents		Threaded	3,5	149	ASTM B62 Bronze	TS-2	3,5			•	•					AV-408
	AV-11, AV-13 Hydronic System Air Vents		Screwed	3,5 10	99	Brass	AV-11 AV-13	3,5 10	•		•	•					AV-411

★ 1/4" outlet connection ★★ 1/2" outlet connection † Side connection available ▲ Alternate inlet 1/2"
 †† Side connection not available ††† Flange selection may limit pressure and temperature rating.
 All models comply with the Pressure Equipment Directive PED 97/23/EC. For details, see specific product page or Armstrong PED Certificate.

Air Vents

1-AVC See-Thru Air Vent

For Pressures to 10 bar or Specific Gravity Down to 0,80

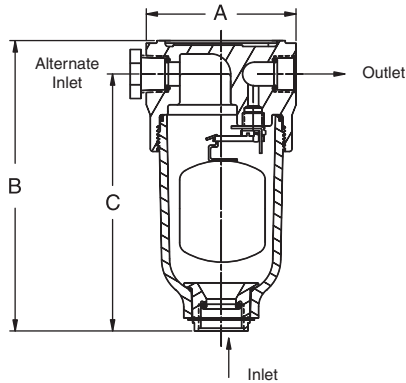

1-AVC



A See-Thru Body – So You'll Know When It's Working

Now, you can literally see what you've been missing – the early warning signs of a system problem. Since you'll know the operating condition of the air vent, you won't have to waste time and money scheduling maintenance that isn't needed. In other words, you will be able to react to a condition before it becomes a problem.

A simple ball float mechanism requiring no electricity to operate, the new Armstrong 1-AVC discharges automatically only when air/gas are present. That means no liquid loss as with manual venting.

An Inside Look

See-thru body means you can observe changing conditions as they occur. See a problem in the making – instead of having to deal with it after the fact.

Efficient Operation

Simple ball float mechanism discharges only when air is present so it doesn't waste liquid.

Positive Seating

Free-floating valve mechanism assures positive seating so it prevents liquid loss. There are no fixed pivots to wear or create friction, and wear points are heavily reinforced for long life.

Reduced Maintenance

Stainless steel internals mean corrosion resistance and reduced maintenance.

Corrosion Resistance

Long-lasting polysulfone body and reinforced nylon cap resist corrosion and provide long, trouble-free service life.

Compare... and Save the Difference

Seeing is really believing – especially when you compare the Armstrong see-thru air vent with manual venting. Measure the differences in the time and money you can save with a more efficient, easier-to-maintain system. For more information or technical assistance, contact your local Armstrong Representative.

Note: The Armstrong 1-AVC should not be used in an environment where there are high levels of ketones or chlorinated or aromatic hydrocarbons.

Table AV-396-1. 1-AVC List of Materials

Name of Part	Material
Cap	Reinforced Nylon
Body	Polysulfone*
O-Rings (Body Cap and Fitting)	Nitrile Elastome Compound
Float Lever and Screws	Stainless Steel
Valve & Seat	Stainless Steel
Fitting & Pipe Plug	Reinforced Nylon
Retainer Ring	Zinc Plated Steel

* UV sensitive.

Table AV-396-2. 1-AVC Physical Data

	mm
Inlet Connection	15 – 20
Outlet Connection	15
"A" Face-to-Face	89
"B" Height	171
"C" Bottom to \varnothing	152
Maximum Allowable Pressure (Vessel Design)	10 bar @ 65°C
Maximum Operating Pressure	10 bar
Specific Gravity Range	1,00 to 0,80
Weight in kg (screwed)	0,45

All sizes comply with the article 3.3 of the PED (97/23/EC).

Table AV-396-3. 1-AVC Capacity

Differential Pressure	Orifice size (in)	m ³ /h
bar		
1,0	1/8"	7,3
2,0		11,0
3,5		16,1
5,0		22,2
7,0		28,7
8,5		34,8
10,0		41,1

Note: Discharge of air through an orifice in m³/h at a standard atmospheric pressure of 1 bar(a) and 21°C.

All dimensions and weights are approximate. Use certified print for exact dimensions. Design and materials are subject to change without notice.

Fixed Pivot Ball Float Air/Gas Vents

For Pressures to 41 bar or Specific Gravity Down to 0,83

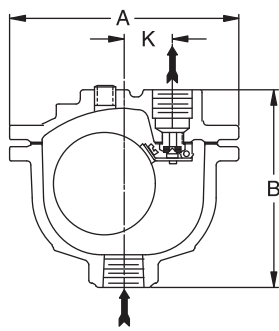

Model 21-AR

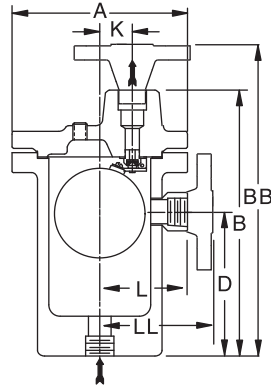

Model 21-312 AR/VAR



21-AR – A small, high-quality economical air vent. It employs a single lever with a fixed pivot and viton seat, ensuring a tight shut-off.

21-312 AR/VAR – Forged steel version of the Model 21 with a larger float and higher leverage. Available with screwed, socketweld or flanged connections.

Model No.	Cast Iron	Forged Steel
	21-AR	21-312 AR/VAR
Pipe Connections	mm	mm
	15 – 20	15 – 20
“A”	157	171
“B”	133	260
“BB” (PN100*)	N/A	300 – 305
“D”	–	141
“K”	33	32
“L”	–	84
“LL” (PN100*)	N/A	124 – 129
Weight in kg (screwed & SW)	4	14
Weight in kg (flanged PN100*)	N/A	15,8 – 17,8
Maximum Allowable Pressure (Vessel Design)	17 bar @ 232°C**	41 bar @ 38°C 34 bar @ 399°C

* Other flange sizes, ratings and face-to-face dimensions are available on request.

** Viton valve seat insert limited to 204°C.

All models comply with the article 3.3 of the PED (97/23/EC).

Minimum Specific Gravity	0,49	0,84
Float weight in grams	64	118
Orifice (in)	Maximum Operating Pressure in bar	
7/32"	1,2	–
3/16"	1,6	–
5/32"	2,3	–
9/64"	2,8	–
1/8"	3,6	–
3/32"	6,4	–
5/64"	9,2	–
1/16"	14,0	–
1/16"	–	17,0

Model	Minimum Specific Gravity	0,83
	Float weight in grams	143
Orifice (in)	Maximum Operating Pressure in bar	
	21-312 AR	1/4"
7/32"		1,9
3/16"		2,7
5/32"		3,8
9/64"		4,7
32-312 VAR	1/8"	12,0
	3/32"	21,0
	5/64"	31,0
	1/16"	41,0

Model No.	Valve	Seat	Leverage System	Float	Body & Cap	Gasket	Bolting
21-AR	Stainless Steel	Stainless Steel with *Viton Insert	Stainless Steel	Stainless Steel	ASTM A48 Class 30 Cast Iron	Non-Asbestos	Bolts SAE Gr. 2 Nuts ASTM A563 Gr. A
21-312 AR 21-312 VAR					ASTM A105 Forged Steel		Bolts and Nuts ASTM B633 Type 1

Note: Above vents available in T-316 SS bodies and caps and all SS internals. Aluminum body and cap available for Model 21-AR only.

* Other seat insert materials available. Consult factory.

All dimensions and weights are approximate. Use certified print for exact dimensions. Design and materials are subject to change without notice.

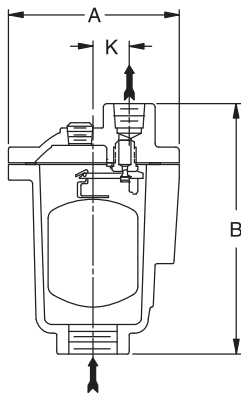

Model 1-AV

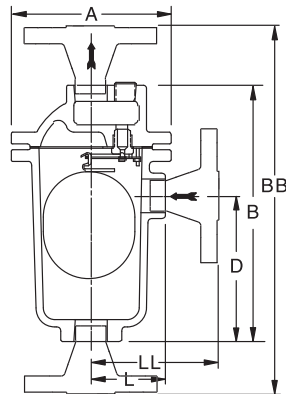

Model 2-AV, 3-AV and 6-AV



Armstrong free floating lever Air/Gas Vents use the same bodies, caps, lever mechanisms, valves and seats of Armstrong inverted bucket steam traps that have been proven in years of service.

Elliptical floats and high leverage make it possible to open large orifices to provide adequate capacity for vent size and weight. The hemispherical valve, seat and leverage are identical in design, materials and workmanship to those for saturated steam service up to 69 bar, with the exception of the addition of a guidepost to assure a positive, leaktight valve closing under all conditions.

1-AV – A cast iron air vent that uses a positive-closing free floating lever to ensure leaktight closing under all conditions. This vent is good for low capacity air/gas venting up to 21 bar.

2-AV, 3-AV and 6-AV – Cast iron vents using the same proven free floating lever mechanisms used in Armstrong steam traps. For applications where high air/gas venting capacity is required up to 17 bar.

Table AV-398-1. Physical Data

Model No.	Cast Iron			
	1-AV**	2-AV	3-AV	6-AV
Pipe Connections	mm	mm	mm	mm
	15* – 20*	15 – 20	20 – 25	40 – 50
"A"	89	133	162	259
"B"	140	203	273	432
"BB" (PN40***)	N/A	320 – 330	400 – 392	562 – 568
"D"	–	111	155	213
"K"	21	–	–	–
"L"	–	62	73	123
"LL" (PN40***)	N/A	179 – 189	203 – 195	180 – 186
Weight in kg (screwed)	1,8	6	10	36
Weight in kg (flanged PN40***)	N/A	8,7 – 9,6	13,6 – 14,2	42,6 – 45,0
Maximum Allowable Pressure (Vessel Design)	21 bar @ 93°C 17 bar @ 232°C	17 bar @ 232°C	17 bar @ 232°C	17 bar @ 232°C

* Outlet connection 1/4".

** 1-AV available with side connection if specified on order. On models 2-AV, 3-AV and 6-AV, pipe size of side connections is same as that of inlet and outlet connections. Some floats are oil filled. Consult factory for details.

*** Other flange sizes, ratings and face-to-face dimensions are available on request.

Shade indicates products that are CE Marked according to the PED (97/23/EC). All the other models comply with the Article 3.3 of the same directive.

Table AV-398-2. List of Materials

Model No.	Valve & Seat	Leverage System	Float	Body & Cap	Gasket	Bolts	Nuts
1-AV	Stainless Steel			ASTM A48 Class 30 Cast Iron	Non-asbestos	ASTM A193 Gr. B7	ASTM A563 Gr. A
2-AV						SAE Gr. 2	
3-AV							
6-AV							

All dimensions and weights are approximate. Use certified print for exact dimensions. Design and materials are subject to change without notice.

Free Floating Lever Air/Gas Vents – Cast Iron

For Pressures to 21 bar or Specific Gravity Down to 0,40



Minimum Specific Gravity	0,80
Orifice Size (in)	Maximum Operating Pressure in bar
1/8"	10
7/64"	12
#38	15
5/64"	21

Maximum Operating Pressures of free floating lever vents with weighted floats for different orifice sizes, and the specific gravities on which they can be used.

Specific Gravity*	1,00	0,95	0,90	0,85	0,80	0,75	0,70	0,65	0,60	0,55	0,50
Float weight in grams	217	206	195	184	174	163	152	141	130	119	109
Orifice Size (in)	Maximum Operating Pressure in bar										
5/46"	1,8	1,8	1,7	1,6	1,5	1,4	1,3	1,2	1,1	1,0	0,9
1/4"	3,0	2,9	2,7	2,6	2,4	2,3	2,1	2,0	1,8	1,7	1,5
3/16"	6,7	6,4	6,0	5,7	5,4	5,0	4,7	4,4	4,1	3,7	3,4
5/32"	12,0	11,0	10,4	9,8	9,3	8,7	8,1	7,6	7,0	6,4	5,8
1/8"	17,0	17,0	17,0	17,0	16,0	15,0	14,0	13,0	12,0	11,0	10,0
7/64"	17,0	17,0	17,0	17,0	17,0	17,0	17,0	17,0	15,0	14,0	13,0
#38	17,0	17,0	17,0	17,0	17,0	17,0	17,0	17,0	17,0	17,0	16,0
5/64"	17,0	17,0	17,0	17,0	17,0	17,0	17,0	17,0	17,0	17,0	17,0

Specific Gravity	1,00	0,95	0,90	0,85	0,80	0,75	0,70	0,65	0,60
Float weight in grams	423	402	381	360	339	318	296	275	254
Orifice Size (in)	Maximum Operating Pressure in bar								
1/2"	1,5	1,4	1,3	1,3	1,2	1,1	1,0	1,0	0,9
3/8"	3,1	3,0	2,8	2,7	2,5	2,3	2,2	2,0	1,9
5/16"	5,0	4,7	4,5	4,2	4,0	3,8	3,5	3,3	3,0
9/32"	6,6	6,3	6,0	5,6	5,3	5,0	4,7	4,3	4,0
1/4"	9,9	9,4	8,9	8,5	8,0	7,5	7,0	6,5	6,0
7/32"	14,0	13,0	13,0	12,0	11,0	10,7	10,0	9,3	8,6
3/16"	17,0	17,0	17,0	17,0	17,0	16,0	15,0	14,0	13,0
5/32"	17,0	17,0	17,0	17,0	17,0	17,0	17,0	17,0	17,0

Specific Gravity*	1,00	0,95	0,90	0,85	0,80	0,75	0,70	0,65	0,60	0,55	0,50	0,45	0,40
Float weight in grams	2 084	1 979	1 875	1 771	1 667	1 563	1 459	1 354	1 250	1 146	1 042	938	833
Orifice Size (in)	Maximum Operating Pressure in bar												
1 1/6"	1,5	1,5	1,4	1,3	1,2	1,2	1,1	1,0	0,9	0,8	0,8	0,7	0,62
7/8"	2,4	2,3	2,2	2,0	1,9	1,8	1,7	1,6	1,5	1,3	1,2	1,1	1,0
3/4"	3,5	3,3	3,1	3,0	2,8	2,6	2,4	2,3	2,1	1,9	1,8	1,6	1,4
5/8"	5,3	5,0	4,8	4,5	4,3	4,0	3,7	3,5	3,2	2,9	2,7	2,4	2,2
9/16"	7,0	6,7	6,3	6,0	5,6	5,3	4,9	4,6	4,2	3,9	3,6	3,2	3,9
1/2"	10,2	9,7	9,2	8,7	8,2	7,7	7,2	6,7	6,2	5,6	5,1	4,6	4,1
7/16"	14,0	14,0	13,0	12,0	12,0	11,0	10,2	9,5	8,7	8,0	7,3	6,6	5,9
3/8"	17,0	17,0	17,0	17,0	17,0	17,0	16,0	15,0	14,0	13,0	12,0	10,4	9,3
11/32"	17,0	17,0	17,0	17,0	17,0	17,0	17,0	17,0	17,0	17,0	15,0	14,0	12,0
5/16"	17,0	17,0	17,0	17,0	17,0	17,0	17,0	17,0	17,0	17,0	17,0	17,0	16,0
9/32"	17,0	17,0	17,0	17,0	17,0	17,0	17,0	17,0	17,0	17,0	17,0	17,0	17,0
1/4"	17,0	17,0	17,0	17,0	17,0	17,0	17,0	17,0	17,0	17,0	17,0	17,0	17,0

* If specific gravity falls between those shown, use next lowest: e.g., if actual gravity is 0,73, use 0,70 specific gravity data.



Free Floating Lever Air/Gas Vents – Forged Steel

For Pressures to 69 bar or Specific Gravity Down to 0,40

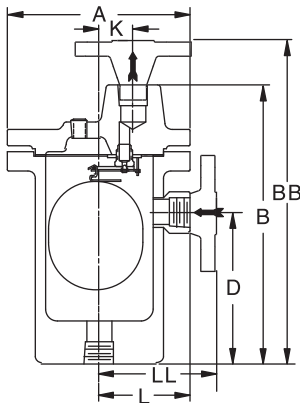

Model 32-AV, 33-AV and 36-AV



32-AV, 33-AV and 36-AV – Forged steel vents using the same proven free floating lever mechanisms used in Armstrong steam traps.

For applications where high air/gas venting capacity is required up to 69 bar. Available with screwed, socketweld or flanged connections.

Table AV-400-1. 30-AV Series List of Materials

Model No.	Valve & Seat	Leverage System	Float	Body & Cap	Gasket	Bolting
32-AV	Stainless Steel			ASTM A105 Forged Steel	Non-asbestos	Bolts ASTM A193 Gr. B7 Nuts ASTM A194 Gr. 2H
33-AV						
36-AV						

Table AV-400-2. 30-AV Series Physical Data

Model No.	Forged Steel		
	32-AV †	33-AV †	36-AV †
Pipe Connections	15 – 20	20 – 25	40 – 50
“A”	171	203	301
“B”	259	295	435
“BB” (PN100*)	300 – 305	343 – 349 – 355	500 – 505
“D”	141	154	229
“K”	32	37	54
“L”	86	98	154
“LL” (PN100*)	127 – 132	145 – 153 – 159	198 – 204
Weight in kg (screwed & SW)	14	22	74
Weight in kg (flanged PN100*)	15,8 – 17,8	25,0 – 26,0	83,2 – 87,2
Maximum Allowable Pressure (Vessel Design)	41 bar @ 38°C 34 bar @ 399°C	69 bar @ 38°C 41 bar @ 399°C	

† Available in Type 316 SS. Consult factory. Pipe size of side connections if provided is same as that of inlet and outlet connections. Some floats are oil filled. Consult factory for details.

* Other flange sizes, ratings and face-to-face dimensions are available on request.

Shade indicates products that are CE Marked according to the PED (97/23/EC). All the other models comply with the Article 3.3 of the same directive.

Air Vents

All dimensions and weights are approximate. Use certified print for exact dimensions. Design and materials are subject to change without notice.

Armstrong International SA • Parc Industriel des Hauts-Sarts (2^e Avenue) • 4040 Herstal • Belgium

Tel.: +32 (0)4 240 90 90 • Fax: +32 (0)4 240 40 33

www.armstronginternational.eu • info@armstronginternational.eu

Free Floating Lever Air/Gas Vents – Forged Steel

For Pressures to 69 bar or Specific Gravity Down to 0,40



High-Temperature Service

Maximum allowable working pressures of floats decrease at temperatures above 38°C. Allow for approximately:

- 10% decrease at 93°C
- 15% decrease at 147°C
- 20% decrease at 204°C

The float is not always the limiting factor, however. Consult with Armstrong Application Engineering if you have a high-temperature application that also requires maximum operating pressures.

Sour Gas Service

Forged steel and stainless steel traps can be modified to resist hydrogen sulfide stress corrosion. These modifications involve annealing the float, which will reduce the maximum working pressure of the float to about half of its normal value. Consult Armstrong Application Engineering for allowable working pressures.

Maximum Operating Pressures of free floating lever vents with weighted floats for different orifice sizes, and the specific gravities on which they can be used.

Specific Gravity	1,00	0,95	0,90	0,85	0,80	0,75	0,70	0,65
Float weight in grams	335	318	301	285	268	251	234	218
Orifice Size (in)	Maximum Operating Pressure in bar							
5/16"	2,8	2,7	2,6	2,4	2,3	2,1	2,0	1,9
1/4"	4,7	4,4	4,2	4,0	3,7	3,5	3,3	3,0
3/16"	10,3	9,8	9,3	8,8	8,2	7,7	7,2	6,7
5/32"	18,0	17,0	16,0	15,0	14,0	13,0	12,0	12,0
1/8"	30,0	29,0	27,0	26,0	24,0	23,0	21,0	20,0
7/64"	39,0	37,0	35,0	33,0	31,0	29,0	27,0	25,0
#38	41,0	41,0	41,0	41,0	39,0	36,0	34,0	31,0
5/64"	41,0	41,0	41,0	41,0	41,0	41,0	41,0	41,0

Specific Gravity*	1,00	0,95	0,90	0,85	0,80	0,75	0,70	0,65	0,60
Float weight in grams	423	402	381	360	339	318	296	275	254
Orifice Size (in)	Maximum Operating Pressure in bar								
1/2"	1,5	1,4	1,3	1,3	1,2	1,1	1,0	1,0	0,9
3/8"	3,1	3,0	2,8	2,7	2,5	2,3	2,2	2,0	1,9
5/16"	5,0	4,7	4,5	4,2	4,0	3,8	3,5	3,3	3,0
9/32"	6,6	6,3	6,0	5,6	5,3	5,0	4,7	4,3	4,0
1/4"	9,9	9,4	8,9	8,5	8,0	7,5	7,0	6,5	6,0
7/32"	14,0	13,0	13,0	12,0	11,0	10,7	10,0	9,3	8,6
3/16"	21,0	20,0	19,0	18,0	17,0	16,0	15,0	14,0	13,0
5/32"	33,0	32,0	30,0	28,0	27,0	25,0	24,0	22,0	20,0
1/8"	62,0	62,0	61,0	58,0	54,0	51,0	48,0	44,0	41,0
7/64"	62,0	62,0	62,0	62,0	62,0	62,0	61,0	57,0	52,0

Specific Gravity*	1,00	0,95	0,90	0,85	0,80	0,75	0,70	0,65	0,60	0,55	0,50	0,45	0,40
Float weight in grams	2 084	1 979	1 875	1 771	1 667	1 563	1 459	1 354	1 250	1 146	1 042	938	833
Orifice Size (in)	Maximum Operating Pressure in bar												
1 1/16"	1,5	1,5	1,4	1,3	1,2	1,2	1,1	1,0	0,9	0,8	0,8	0,7	0,62
7/8"	2,4	2,3	2,2	2,0	1,9	1,8	1,7	1,6	1,5	1,3	1,2	1,1	1,0
3/4"	3,5	3,3	3,1	3,0	2,8	2,6	2,4	2,3	2,1	1,9	1,8	1,6	1,4
5/8"	5,3	5,0	4,8	4,5	4,3	4,0	3,7	3,5	3,2	2,9	2,7	2,4	2,2
9/16"	7,0	6,7	6,3	6,0	5,6	5,3	4,9	4,6	4,2	3,9	3,6	3,2	3,9
1/2"	10,2	9,7	9,2	8,7	8,2	7,7	7,2	6,7	6,2	5,6	5,1	4,6	4,1
7/16"	14,0	14,0	13,0	12,0	12,0	11,0	10,2	9,5	8,7	8,0	7,3	6,6	5,9
3/8"	23,0	22,0	21,0	19,0	18,0	17,0	16,0	15,0	14,0	13,0	12,0	10,4	9,3
11/32"	30,0	29,0	27,0	26,0	24,0	23,0	21,0	20,0	18,0	17,0	15,0	14,0	12,0
5/16"	39,0	37,0	35,0	33,0	31,0	29,0	27,0	26,0	24,0	17,0	17,0	17,0	16,0
9/32"	51,0	49,0	46,0	44,0	41,0	39,0	36,0	33,0	31,0	17,0	17,0	17,0	17,0
1/4"	69,0	69,0	67,0	64,0	60,0	56,0	53,0	49,0	45,0	17,0	17,0	17,0	17,0
7/32"	69,0	69,0	69,0	69,0	69,0	69,0	69,0	69,0	64,0	17,0	17,0	17,0	17,0
3/16"	69,0	69,0	69,0	69,0	69,0	69,0	69,0	69,0	69,0	17,0	17,0	17,0	17,0

* If specific gravity falls between those shown, use next lowest: e.g., if actual gravity is 0,73, use 0,70 specific gravity data.

High Leverage Ball Float Type Air Relief Traps

For Low Flows at Pressures to 186 bar or Specific Gravity Down to 0,49

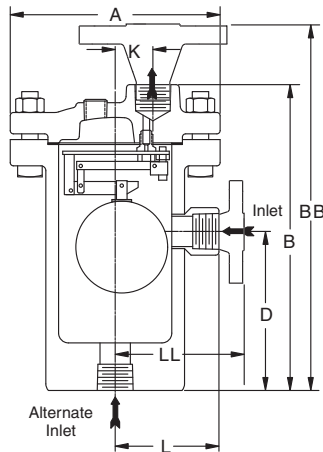

The Armstrong High Leverage Series of Air Relief traps were developed especially for venting gases from low specific gravity fluids at high pressures. They use standard Armstrong forged steel bodies with very high leverage air relief mechanisms. Available with screwed, socketweld or flanged connections.

Note: Models 2313-HLAR, 2316-HLAR, 2413-HLAR and 2415-HLAR are also available with cast T-316 stainless steel body and all-stainless steel internals. Consult factory.

Sour Gas Service

Forged steel and stainless steel traps can be modified to resist hydrogen sulfide stress corrosion. These modifications involve annealing the float, which will reduce the maximum working pressure of the float to about half its normal value. Consult Armstrong Application Engineering for allowable working pressures.

Table AV-402-1. Physical Data – High Leverage Ball Float Type Air Relief Traps

Model No.	2313-HLAR	2315-HLAR	2316-HLAR	2413-HLAR	2415-HLAR	2416-HLAR	25133G-HLAR	25155G-HLAR	26155G-HLAR
Pipe Connections	mm	mm	mm	mm	mm	mm	mm	mm	mm
	15 – 20 – 25	25 – 32 – 40	40 – 50	15 – 20 – 25	25 – 32 – 40	40 – 50	15 – 20 – 25	20 – 25 – 32	25 – 32
"A"	203	248	302	219	273	318	216	263	298
"B"	295	381	435	305	379	448	362	412	613
"BB" (PN100 – 160 – 250*)	343 – 349 – 355	442 – 444 – 446	500 – 505	353 – 360 – 366	440 – 444 – 448	515 – 526	472 – 473 – 487	540 – 540 – 540	740 – 740
"D"	154	198	229	137	184	229	75	102	127
"G"	130	175	213	137	175	219	146	187	213
"K"	37	44	54	37	44	54	33	44	44
"L"	98	119	146	102	122	148	–	–	–
"LL" (PN100 – 160*)	145 – 153 – 159	171 – 173 – 175	198 – 204	149 – 156 – 162	181 – 183 – 187	211 – 244	185 – 187 – 190	214 – 214 – 214	224 – 224
Weight in kg (SW)	21	44	73	31	59	95	51	78	147
Weight in kg (flanged PN100 – 160 – 250*)	23,0 – 25,0 – 26,0	46,0 – 50,0 – 53,0	84,2 – 88,2	35,0 – 37,0 – 38,0	60,6 – 64,6 – 67,6	104,0 – 108,0	56,0 – 57,0 – 58,0	101,0 – 102,0 – 103,0	154,2 – 160,2
Maximum Allowable Pressure (Vessel Design)	69 bar @ 38°C 41 bar @ 399°C			103 bar @ 38°C 62 bar @ 454°C	125 bar @ 38°C 62 bar @ 482°C		146 bar @ 38°C 117 bar @ 482°C	159 bar @ 38°C 131 bar @ 482°C	255 bar @ 38°C 207 bar @ 482°C

† Available with cast 316 stainless steel body and all stainless steel internals. Consult factory.

* Other flange sizes, ratings and face-to-face dimensions are available on request.

All standard products are CE Marked according to the PED (97/23/EC).

Table AV-402-2. HLAR Series List of Materials

Model No.	Valve & Seat	Leverage System	Float	Body & Cap	Gasket
2313-HLAR 2315-HLAR 2316-HLAR	Stainless Steel			ASTM A105 Forged Steel	Compressed Asbestos-free
2413-HLAR 2415-HLAR 2416-HLAR				ASTM A182 Grade F22 Forged Steel	
25133G-HLAR 25155G-HLAR 26155G-HLAR					

Table AV-402-3. 2315-HLAR Maximum Operating Pressures

Specific Gravity	1,00 – 0,61		0,60 – 0,49	
Float weight in grams	255		191	
Orifice size (in)	Maximum Operating Pressure in bar			
3/16"	56		41	
5/32"	69			
1/8"				
3/32"				

All dimensions and weights are approximate. Use certified print for exact dimensions. Design and materials are subject to change without notice.

High Leverage Ball Float Type Air Relief Traps

For Low Flows at Pressures to 186 bar or Specific Gravity Down to 0,49



Maximum Operating Pressures of free floating lever vents with weighted floats for different orifice sizes, and the specific gravities on which they can be used.

Specific Gravity	1,00 – 0,69	0,68 – 0,54
Float weight in grams	191	135
Orifice size (in)	Maximum Operating Pressure in bar	
1/8"	69	33
7/64"		
3/32"		
5/64"		
1/16"		

Specific Gravity	1,00 – 0,61	0,60 – 0,49
Float weight in grams	624	439
Orifice size (in)	Maximum Operating Pressure in bar	
7/32"	69	33
3/16"		
5/32"		
1/8"		
3/32"		

Specific Gravity	1,00 – 0,90	0,89 – 0,69	0,68 – 0,54
Float weight in grams	266	191	135
Orifice size (in)	Maximum Operating Pressure in bar		
1/8"	103	69	33
7/64"			
3/32"			
5/64"			
1/16"			

Specific Gravity	1,00 – 0,70	0,69 – 0,55
Float weight in grams	624	439
Orifice size (in)	Maximum Operating Pressure in bar	
7/32"	103	33
3/16"		
5/32"		
1/8"		
3/32"		

Specific Gravity	1,00 – 0,85	0,84 – 0,61	0,60 – 0,49
Float weight in grams	390	255	191
Orifice size (in)	Maximum Operating Pressure in bar		
3/16"	83	56	41
5/32"	119	80	
1/8"	124	83	
3/32"			

Specific Gravity	1,00 – 0,98	0,97 – 0,90	0,89 – 0,69	0,68 – 0,54
Float weight in grams	298	266	191	135
Orifice size (in)	Maximum Operating Pressure in bar			
1/8"	146	103	69	33
7/64"				
3/32"				
5/64"				
1/16"				

Specific Gravity	1,00 – 0,95	0,94 – 0,86	0,85 – 0,63	0,62 – 0,50
Float weight in grams	437	390	262	191
Orifice size (in)	Maximum Operating Pressure in bar			
3/16"	93	83	58	41
5/32"	132	119	82	
1/8"	172	138	83	
3/32"				

Specific Gravity	1,00 – 0,95	0,94 – 0,86	0,85 – 0,63	0,62 – 0,50
Float weight in grams	437	390	262	191
Orifice size (in)	Maximum Operating Pressure in bar			
3/16"	93	83	58	41
5/32"	132	119	82	
1/8"	186	138	83	
3/32"				



Free Floating Lever Air/Gas Vents – All Stainless Steel

For Pressures to 41 bar or Specific Gravity Down to 0,50

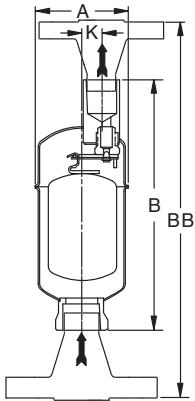

Model 11-AV

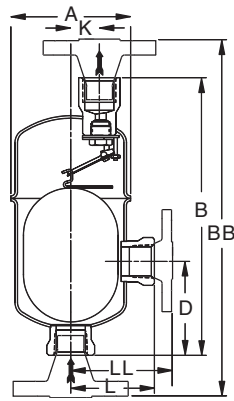

Model 22-AV and 13-AV



The Armstrong all-stainless steel guided lever air vents have been developed to provide positive venting of air/gases under pressure.

The body and cap and all working parts of the models 11-AV, 22-AV and 13-AV are made of high strength, corrosion resistant stainless steel. Body and caps are welded together to form a permanently sealed, tamperproof unit with no gaskets. Elliptical floats and high leverage provide up to 195 m³/h capacity for these compact air/gas vents. Lever action is guided to assure proper seating of the valve under all operating conditions.

11-AV, 22-AV and 13-AV – All stainless steel construction where exposure to either internal or external corrosion is a problem. These air/gas vents have the same proven free floating mechanisms used in other Armstrong steam traps. Pressures to 41 bar @ 38°C.

Table AV-404-1. 10-AV Series Physical Data

Model No.	11-AV	22-AV	13-AV
Pipe Connections	15 – 20**	20	25
"A"	70	99	114
"B"	183	221	289
"BB" (PN40*)	225 – 230	271	375
"D"	–	86	156
"K"	14	22	30
"L"	–	67	83
"LL" (PN40*)	–	117	126
Weight in kg (screwed & SW)	0,80	2,3	3,4
Weight in kg (flanged PN40*)	2,9 – 4,0	5,2	7,3
Maximum Allowable Pressure (Vessel Design)	34 bar @ 38°C 30 bar @ 260°C	41 bar @ 38°C 33 bar @ 260°C	39 bar @ 38°C 34 bar @ 360°C

* Standard flanges are in carbon steel, stainless steel flanges are optional. Other flange sizes, ratings and face-to-face dimensions are available on request.

** 1/2" outlet.

Shade indicates products that are CE Marked according to the PED (97/23/EC). All the other models comply with the Article 3.3 of the same directive.

Table AV-404-2. 10-AV Series List of Materials

Model No.	Valve & Seat	Leverage System	Float	Body & Cap
11-AV	*440	303/304	304	Sealed
22-AV	Stainless	Stainless	Stainless	Stainless Steel
13-AV	Steel	Steel	Steel	304-L

* Type 316 SS valve and seat available. Consult factory.

All dimensions and weights are approximate. Use certified print for exact dimensions. Design and materials are subject to change without notice.

Free Floating Lever Air/Gas Vents – All Stainless Steel

For Pressures to 41 bar or Specific Gravity Down to 0,50



Maximum Operating Pressures of free floating lever vents with weighted floats for different orifice sizes, and the specific gravities on which they can be used.

Minimum Specific Gravity	0,75	0,50
Float weight in grams	82 – Standard	59 – Special
Orifice Size (in)	Maximum Operating Pressure in bar	
1/8"	12	8
#38	18	12
5/64"	28	21

Specific Gravity*	1,00	0,95	0,90	0,85	0,80	0,75	0,70	0,65	0,60	0,55	0,50
Float weight in grams	282	268	254	240	226	212	152	141	130	119	109
Orifice Size (in)	Maximum Operating Pressure in bar										
5/16"	2,4	2,3	2,2	2,0	1,9	1,8	1,3	1,2	1,1	1,0	0,9
1/4"	3,9	3,7	3,5	3,4	3,2	3,0	2,1	2,0	1,8	1,7	1,5
3/16"	8,7	8,2	7,8	7,4	7,0	6,5	4,7	4,4	4,1	3,7	3,4
5/32"	14,9	14,2	13,5	12,7	12,0	11,2	8,1	7,6	7,0	6,4	5,8
1/8"	25,6	24,3	23,0	21,8	20,5	19,2	13,9	12,9	12,0	11,0	10,0
7/64"	32,7	31,1	29,5	27,9	26,2	24,6	17,8	16,5	15,3	14,0	12,8
#38	40,7	38,7	36,7	34,7	32,7	30,6	22,1	20,6	19,0	17,5	15,9
5/64"	41,4	41,4	41,4	41,4	41,4	41,4	32,6	30,3	28,1	25,8	23,5

Specific Gravity*	1,00	0,95	0,90	0,85	0,80	0,75	0,70	0,65	0,60
Float weight in grams	423	402	381	360	339	318	296	275	254
Orifice Size (in)	Maximum Operating Pressure in bar								
1/2"	1,5	1,4	1,3	1,3	1,2	1,1	1,0	1,0	0,9
3/8"	3,1	3,0	2,8	2,7	2,5	2,3	2,2	2,0	1,9
5/16"	5,0	4,7	4,5	4,2	4,0	3,8	3,5	3,3	3,0
9/32"	6,6	6,3	6,0	5,6	5,3	5,0	4,7	4,3	4,0
1/4"	9,9	9,4	8,9	8,5	8,0	7,5	7,0	6,5	6,0
7/32"	14,0	13,0	13,0	12,0	11,0	10,7	10,0	9,3	8,6
3/16"	21,0	20,0	19,0	18,0	17,0	16,0	15,0	14,0	13,0
5/32"	33,0	32,0	30,0	28,0	27,0	25,0	24,0	22,0	20,0
1/8"	39,0	39,0	39,0	39,0	39,0	39,0	39,0	39,0	39,0
7/64"	39,0	39,0	39,0	39,0	39,0	39,0	39,0	39,0	39,0

* If specific gravity falls between those shown, use next lowest: e.g., if actual gravity is 0,73, use 0,70 specific gravity data.

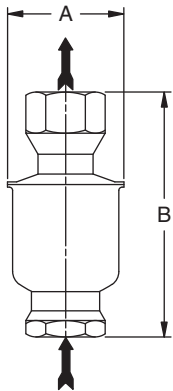

TTF-1
Straight-Thru

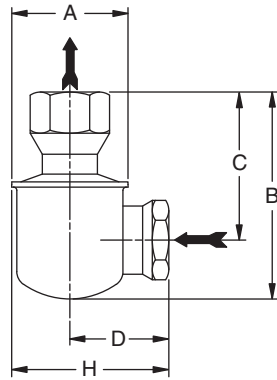

TTF-1R
Right Angle



Armstrong offers Thermostatic Air Vents for positive venting of air and other non-condensable gases from steam in chamber type heat transfer equipment. Typical applications include jacketed kettles, retorts, vulcanizers, jacketed sterilizers or other contained equipment where air could accumulate in remote areas of the steam chamber and reduce heat transfer capacity. These vents are balanced pressure air vents that respond to the pressure-temperature curve of steam. Air is automatically vented at slightly below steam temperature throughout the entire operating pressure range.

Features

- Suitable for pressures from 0 to 20 bar
- All 304-L stainless steel bodies – sealed, tamper-proof
- Balanced pressure thermostatic element vents air at slightly below steam temperature over the entire pressure range – no adjustments required
- Dependable, proven phosphor-bronze bellows caged in stainless steel with bronze valve and stainless steel seat
- Available in straight-thru or right-angle connections

Armstrong thermostatic air vents should be installed at the highest point on a steam chamber, with the air vent located above the chamber. This will minimize the possibility of any liquid carryover, and air can be vented at atmosphere without a drain line.

Table AV-406-1. TTF-1 List of Materials

Name of Part	Material
Body	304-L Stainless steel
Connections	304 Stainless steel
Balanced Pressure Thermostatic Air Vent	Stainless steel and bronze with Phosphor-bronze bellows, entire unit caged in stainless steel
Gasket	Copper clad non-asbestos

Optional: All stainless steel thermostatic air vent.

Table AV-406-2. TTF-1 Physical Data

Model No.	Straight-thru Connections TTF-1		Right-Angle Connections TTF-1R	
	mm	mm	mm	mm
Pipe Connections	15	20	15	20
"A" Diameter	57	57	57	57
"B" Height	114	119	95	100
"C" \varnothing inlet to face of outlet	–	–	67	71
"D" \varnothing outlet to face of inlet	–	–	49	48
"H"	–	–	78	76
Weight in kg (screwed)	0,4	0,5	0,4	0,5
Maximum Allowable Pressure (Vessel Design)	20 bar @ 232°C			
Maximum Operating Pressure	20 bar			
Discharge Orifice Size	3/16"			

All models comply with the article 3.3 of the PED (97/23/EC).

All dimensions and weights are approximate. Use certified print for exact dimensions. Design and materials are subject to change without notice.

Stainless Steel Thermostatic Air Vent/Vacuum Breaker

For Pressures to 10 bar...Capacities to 93 m³/h

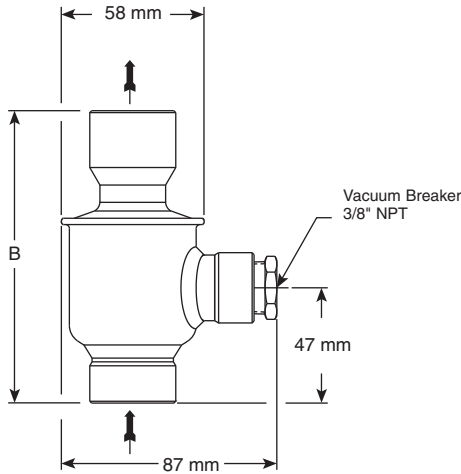

The Armstrong TAVB is a combination thermostatic air vent/vacuum breaker that is ideally suited for steam-filled vessels with modulating controls. The TAVB will vent air and other non-condensables from vessels such as shell and tube heat exchangers, jacketed kettles and steam coils during their operation. It will also break the vacuum that forms during steam control modulation.

This balanced pressure air vent responds to the pressure-temperature curve of steam, and the soft-seated vacuum breaker responds to 0,0051 bar of vacuum.

Features

- Maximum allowable pressure: 20 bar
- Maximum allowable temperature: 185°C
- Maximum working pressure: 10 bar
- All stainless steel welded construction
- NPT connections

Armstrong thermostatic air vents should be installed at the highest point on a steam chamber, with the air vent located above the chamber. This will minimize the possibility of any liquid carryover, and air can be vented to atmosphere without a drain line.

Table AV-407-1. TAVB Physical Data (dimensions in mm)

Model No.		TAVB-2	TAVB-3
Pipe Connections	Thermostatic Air Vent	15	20
	Vacuum Breaker	3/8"	3/8"
"A" (Diameter)		57	57
"B" (Height)		117	119
"C" (∅ Inlet to Face of Vacuum Breaker)		54	54
Weight lb (kg)		0,45	0,57
Maximum Allowable Pressure (Vessel Design)		20 bar @ 185°C	
Maximum Operating Pressure		10 bar	
Discharge Orifice Size		3/16"	

Table AV-407-2. TAVB List of Materials

Name of Part	Material
Body	304L Stainless Steel
Connections	304 Stainless Steel
Balanced Pressure Thermostatic Air Vent	Stainless steel and bronze with phosphor-bronze bellows, entire unit caged in stainless steel
Gasket	Copper clad non-asbestos
Vacuum Breaker Body	303 Stainless Steel
Valve	Stainless Steel
Spring	302 Stainless Steel
"O" Ring	EPDM
Screen	Stainless Steel

All sizes comply with the article 3.3 of the PED (97/23/EC).

All dimensions and weights are approximate. Use certified print for exact dimensions. Design and materials are subject to change without notice.

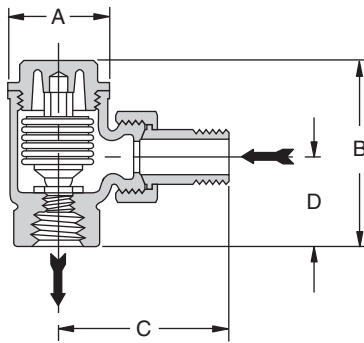

TS-2 Air Vent Angle Type

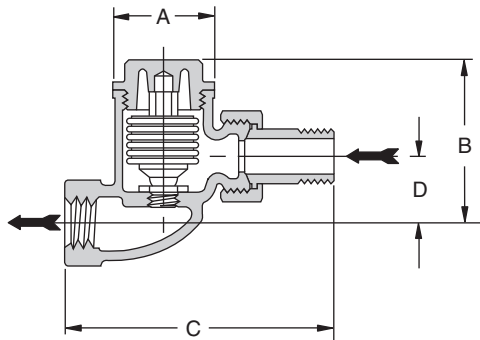

TS-2 Air Vent Straight Type



Armstrong TS thermostatic air vent is offered in both angle and straight patterns. The TS-2 has a balanced pressure thermostatic element with a high quality multiple-convolution bellows. It's ideal for venting air from equipment such as steam radiators and convectors, small heat exchangers, and unit heaters. The TS-2 comes with a strong, cast bronze body and a stainless steel seat. The valve and seat are renewable in-line.

Materials

Cap:	Bronze, ASTM B62
Body:	Bronze, ASTM B62
Union Nipple:	Brass, ASTM B584
Valve:	Brass
Valve Seat:	Stainless steel
Element:	Phosphor-bronze bellows

Table AV-408-1. TS-2 Physical Data

Model	TS-2			
	Angle		Straight	
Pattern	mm	mm	mm	mm
Pipe connections	15	20	15	20
"A" Diameter	41	41	41	41
"B" Height	75	76	68	73
"C"	65	73	102	114
"D"	35	41	28	33
Weight in kg (screwed)	0,68	0,79	0,68	0,91

All sizes comply with the article 3.3 of the PED (97/23/EC).

All dimensions and weights are approximate. Use certified print for exact dimensions. Design and materials are subject to change without notice.

TV-2 Thermostatic Air Vent

For Pressures to 9 bar...Capacities to 78 m³/h

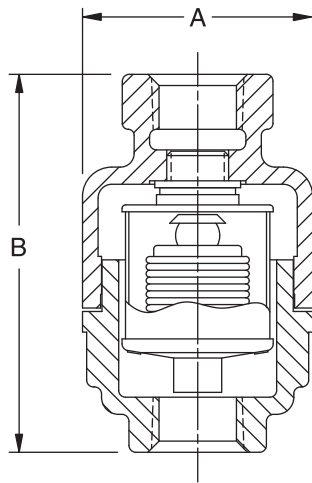

**TV-2
Thermostatic Air Vent**



Armstrong offers the Model TV-2 Balanced Pressure Thermostatic Air Vent for positive venting of air from chamber type heat transfer equipment with no loss of steam. Typical applications include jacketed kettles, retorts, vulcanizers, jacketed sterilizers or other contained equipment where air could accumulate at the top of the steam chamber and reduce heat transfer capacity.

The Model TV-2 is a balanced-pressure thermostatic air vent that responds to the pressure-temperature curve of steam at any pressure from light vacuum to maximum operating pressure. Air is automatically vented at slightly below steam temperature throughout the entire operating pressure range.

The thermostatic element is a charged multi-convolution phosphor bronze bellows caged in stainless steel. Valve and seat are also stainless steel designed to meet the most rigid cycling specifications known for this type of service.

Features

- Stainless steel hemispherical valve and seat
- Thermostatic element comprises a multi-convolution phosphor bronze bellows caged in stainless steel
- Thermostatic element is charged with water to provide positive opening of the valve at slightly below steam temperature and positive closing in the presence of steam throughout the operating pressure range
- ASTM B62 cast bronze body

Armstrong Model TV-2 Thermostatic Air Vents should be installed at the highest points of steam chambers with inlet connections to the vents higher than the highest points of the chambers. Thus installed there is a minimum hazard of any liquid carryover and air can be vented to atmosphere with no drain line necessary.

Table AV-409-1. TV-2 Physical Data

Pipe Connections	mm
	15
"A" (Diameter)	56
"B" (Height)	89
Weight in kg (screwed)	0,8
Maximum Operating Pressure	9 bar
Maximum Temperature	177°C

Table AV-409-2. TV-2 Materials

Name of Part	Material
Body & Cap	Cast bronze ASTM B62
Gasket	Compressed non-asbestos
Thermostatic Unit	
Bellows	Phosphor bronze
Cage and Cover	Stainless steel
Thermostatic Unit Gasket	Copper clad

All sizes comply with the article 3.3 of the PED (97/23/EC).

All dimensions and weights are approximate. Use certified print for exact dimensions. Design and materials are subject to change without notice.

What Is Ozone?

Ozone is a gas that forms naturally during thunderstorms when lightning converts normal oxygen molecules (O₂) into ozone (O₃). The fresh, sweet smell in the air after a storm is the smell of ozone. The unstable ozone molecule reacts rapidly with most substances and is an extremely strong natural oxidant.

How Is Commercial Ozone Produced?

Ozone can be formed by exposing air to ultraviolet light; however, the most common method of generating ozone is by passing air through an electrical discharge. Because ozone has strong oxidizing properties, its production requires corrosion-resistant equipment.

How Is Ozone Used in Water Filtration and Purification?

Because ozone is such an effective oxidant, it kills viruses, bacteria, mold, mildew, fungus and germs. Passing ozone through water achieves high purification rates without any chemical residue. Oxygen is the only by-product.

Typical Customer Applications:

- Purifying standing ground water in Third World countries.
- Conditioning water for poultry and livestock.
- Purifying water in the bottled water industry.
- Filtering and purifying water for process applications.

A See-Thru Body Shows You It's Working

Now, you can literally see what you've been missing. The Armstrong 1-AVCW See-Thru Air Vent lets you easily check its operating condition. You won't have to waste time and money scheduling maintenance that isn't needed, and you can quickly react to a condition before it becomes a problem.

Efficient Operation

Simple ball-float mechanism doesn't need electricity to operate. The air vent automatically discharges only when air or gas is present. No liquid is lost, as with manual venting.

Positive Seating

Free-floating valve mechanism ensures positive seating and prevents liquid loss. There are no fixed pivots to wear or create friction. Wear points are heavily reinforced for long life.

Corrosion Resistance

Long-lasting PBT (polybutylene terephthalate) cap provides trouble-free operation. Stainless steel internal parts resist corrosion and reduce maintenance.

Compare – and Save the Difference

Seeing really is believing – especially when you compare the Armstrong 1-AVCW See-Thru Air Vent with manual venting. Measure the time and money you can save with a more efficient, easier-to-maintain system. For more information or technical assistance, contact your local Armstrong Representative.

Note: The Armstrong 1-AVCW should not be used in an environment where there are high levels of ketones or chlorinated or aromatic hydrocarbons.

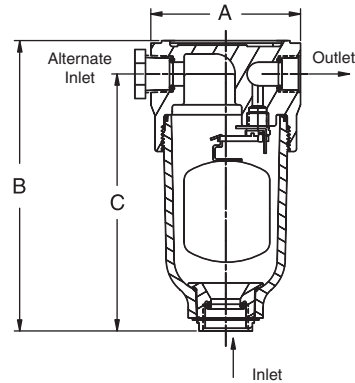

1-AVCW

Table AV-410-1. 1-AVCW List of Materials

Name of Part	Material
Cap	PBT (Polybutylene Terephthalate)
Body	Polysulfone*
O-Rings (Body Cap and Fitting)	Viton
Float Lever and Screws	Stainless Steel
Valve & Seat	Stainless Steel
Fitting	PBT (Polybutylene Terephthalate)
Retainer Ring	Zinc Plated Steel

* UV sensitive

Table AV-410-2. 1-AVCW Physical Data

	mm
Inlet Connection (In Body)	20
Inlet Connection (Alternate)	15
Outlet Connection	15
"A" Face-to-Face	89
"B" Height	172
"C" Bottom to ϕ	152
Maximum Allowable Pressure (Vessel Design)	10 bar @ 66°C
Maximum Operating Pressure	10 bar
Specific Gravity Range	1,00 to 0,80
Weight in kg (screwed)	0,5

All sizes comply with the article 3.3 of the PED (97/23/EC).

Table AV-410-3. 1-AVCW Capacity

Differential Pressure	Orifice Size	m ³ /h
bar		
1,0	1/8"	7,3
2,0		11,0
3,5		16,1
5,0		22,2
7,0		28,7
8,5		34,8
10,5		41,1

Note: Discharge of air through an orifice in m³/h at a standard atmospheric pressure of 1 bar(a) and 21°C.

All dimensions and weights are approximate. Use certified print for exact dimensions. Design and materials are subject to change without notice.

AV-11/AV-13 Air Vents

For Pressures to 10 bar

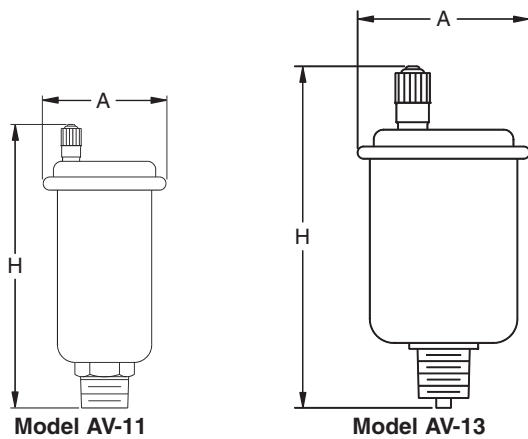

For Hot or Cold Water and Non-Viscous Liquids

Air vent models AV-11 and AV-13 are compact float-type valves for the removal of air and other gases from hydronic heating and cooling systems, liquid chilling operations and other light liquid services.

Table AV-411-1. AV-11 & AV-13 Physical Data

Model	AV-11		AV-13	
	mm	mm	mm	mm
Connection Size	3	15 Female	20 Male	
"A"	44	54	54	
"H"	86	118	118	
Weight in kg (screwed)	0,11	0,23		

All models comply with the article 3.3 of the PED (97/23/EC).

Table AV-411-2. AV-11 & AV-13 Capacities

AV-11		AV-13	
ΔP	Capacities	ΔP	Capacities
bar	m ³ /h	bar	m ³ /h
0,24	0,84	1,1	1,7
0,69	1,7	3,3	3,4
1,7	2,5	5,8	5,1
2,4	3,2	8,3	6,8
3,4	3,4	10,0	8,3

Table AV-411-3. AV-11 & AV-13 Specifications

Model	Application	Working Pressure	Maximum Temperature	Connection	Hydraulic Test Body
		bar	°C		bar
AV-11	Hot or Cold Water	0,06 - 3,4	99	NPT Screwed	14
AV-13		0,06 - 10,3			24

Table AV-411-4. AV-11 & AV-13 Materials

Valve	Float	Disc
Brass	Polypropylene	Nitrile

All dimensions and weights are approximate. Use certified print for exact dimensions. Design and materials are subject to change without notice.